

SECTION C - MISC. PLUMBING SPECIALTIES

Repair	91-92
Test Caps & Plugs	93-94
Flexible Transition Couplings	95
Dishwasher/Washing Machine Parts	96
Dryer Vents.....	97-98
Tape.....	99
Pipe Sleeving/Sand Cloth	100
Rubber Insulation	101-104
Poly Insulation.....	105-107
Insulation Tools/Dielectric Union.....	108
Water Heater Connectors.....	109
Water Heater Supplies.....	110
Pressure Gauges	111-112
Tubing	113
Stud Guards	114-116
Hooks & Nails.....	117
Pipe Strap/Clamps.....	118
Hanger Tape/Packing.....	119
Lead Supplies/Roofing Repair	120
Service Sink Repair	121
Bolts & Screws	122
Washers/Clamps	123
Conduit Hanger	124
Water Meter Supplies	125
Meter Boxes.....	126-127
Boxes	128



Snap-Ease Access Panel



- Can be painted or wallpapered
- Constructed of high-impact white ABS
- Easily installed to eliminate unsightly drywall repairs
- Provides for future access to plumbing or wiring behind wall
- 5/8" depth

PART NO.	SIZE	CTN/MSTR
A04006	6" x 9"	10/80
A05008	8" x 8"	1/10
A05014	14" x 14"	10/30
A05027	14" x 27"	1/6

Plastic Access Panel



- Beveled edges
- Indented screw holes in corners

PART NO.	SIZE	CTN/MSTR
A04012	12" x 12"	1/20

Stainless Steel Repair Clamp



Two Bolt



One Bolt

- Plated lug, carriage bolt and nuts for corrosion protection
- 301 stainless steel clamp with neoprene gaskets for up to 180°F
- Long neck carriage bolts for easy installation

3" One Bolt			
PART NO.	IPS/SCH 40	CTS NOM	CTN/MSTR
R30375	3/8"	1/2"	6/72
R30050	1/2"	3/4"	6/72
R30075	3/4"	1"	6/72
R30100	1"	1 1/4"	6/72
R30125	1 1/4"	1 1/2"	6/72
R30150	1 1/2"	-	6/72
R30200	2"	-	6/72
R30250	2 1/2"	-	6/48
R30300	3"	-	6/36
R30400	4"	-	6/24
R30600	6"	-	1/36
6" Two Bolt			
PART NO.	IPS/SCH 40	CTS NOM	CTN/MSTR
R60375	3/8"	1/2"	6/36
R60050	1/2"	3/4"	6/36
R60075	3/4"	1"	6/36
R60100	1"	1 1/4"	6/36
R60125	1 1/4"	1 1/2"	6/36
R60150	1 1/2"	-	6/36
R60200	2"	-	6/36
R60250	2 1/2"	-	6/24
R60300	3"	-	6/24
R60400	4"	-	6/24
R60600	6"	-	1/20

Malleable Iron Compression Coupling



- EPDM gaskets
- Metal friction ring
- Maximum 125 PSI at 120°F
- Pipe ends must be restrained
- Fits both IPS and Schedule 40 pipe
- Galvanized for corrosion protection

Long Pattern			
PART NO.	IPS	BODY LENGTH	CTN/MSTR
C11050	1/2"	3 3/8"	1/42
C11075	3/4"	3 5/8"	1/32
C11100	1"	3 7/8"	1/24
C11125	1 1/4"	4 1/8"	1/18
C11150	1 1/2"	4 5/16"	1/15
C11200	2"	4 1/2"	1/12
C11250	2 1/2"	6 3/4"	1/4
C11300	3"	7"	1/4
C11400	4"	8 1/8"	1/2

Bronze Compression Coupling



- EPDM gaskets
- Bronze coated brass bodies and nuts
- Maximum 125 PSI at temperatures up to 180°F
- Pipe ends must be restrained on both ends
- For use on galvanized pipe and copper tubing (check sizes)

3" Length			
PART NO.	CTS	IPS	CTN/MSTR
C14050	1/2"	3/8"	1/120
C14075	3/4"	1/2"	12/120
C14100	1"	3/4"	12/72

LEAD FREE			
PART NO.	CTS	IPS	CTN/MSTR
C14205	1/2"	3/8"	1/120
C14206	3/4"	1/2"	12/72
C14207	1"	3/4"	12/72

5" Length			
PART NO.	CTS	IPS	CTN/MSTR
C15050	1/2"	3/8"	1/96
C15075	3/4"	1/2"	12/72
C15100	1"	3/4"	12/48
C15125	1 1/4"	1"	12/48
C15150	1 1/2"	1 1/4"	12/36
C15151	-	1 1/2"	1/36
C15200	2"	-	1/30
C15201	-	2"	12/24

LEAD FREE			
PART NO.	CTS	IPS	CTN/MSTR
C15300	1/2"	3/8"	1/96
C15301	3/4"	1/2"	12/72
C15302	1"	3/4"	12/48
C15303	1 1/4"	1"	12/48
C15304	1 1/2"	1 1/4"	12/36
C15305	-	1 1/2"	12/36
C15306	2"	-	1/30
C15307	-	2"	12/24

PVC Compression Coupling



- For use on cold water lines only
- Ribbed body and nuts for gripping
- Fits IPS and Schedule 40 pipe
- EPDM gaskets
- 150 PSI at 73°F
- Pipe ends must be restrained

PART NO.	IPS	BODY LENGTH	CTN/MSTR
C12050	1/2"	3 3/4"	30/120
C12075	3/4"	3 15/16"	30/120
C12100	1"	4 3/4"	25/100
C12125	1 1/4"	5 3/16"	25/100
C12150	1 1/2"	5 3/8"	15/60
C12200	2"	6"	6/24
C12250	2 1/2"	7 7/8"	1/15
C12300	3"	8"	1/18
C12400	4"	12"	1/4
C12600	6"	11 1/8"	1/2

PVC Expansion Coupling



- Rated 200 PSI

PART NO.	IPS	BODY LENGTH	CTN/MSTR
E09050	1/2"	5 3/4"	1/160
E09075	3/4"	6 3/4"	1/120
E09100	1"	7 3/4"	1/54
E09125	1 1/4"	9"	1/40
E09150	1 1/2"	10"	1/35
E09200	2"	10 1/2"	1/24
E09250	2 1/2"	13"	1/3
E09300	3"	14 1/2"	1/3
E09400	4"	14 1/2"	1/3

CPVC Compression Coupling



- For use on hot water lines
- 100 PSI at temperatures up to 180°F
- Tubing sizes copper and plastic tubing
- EPDM gaskets
- Ribbed body and nuts for gripping
- Pipe ends must be restrained

PART NO.	TUBING SIZE	CTN/MSTR
C13050	1/2" (5/8" OD)	20/360
C13075	3/4" (7/8" OD)	20/240

Compression Tee

Malleable Iron



- Galvanized for corrosion protection
- Metal friction ring
- Compression tees must be restrained on both ends
- Fits both IPS and Schedule 40 pipe
- EPDM gaskets
- FIP branch
- 125 PSI at 120°F

PART NO.	SIZE	CTN/MSTR
C16050	1/2"	1/12
C16075	3/4"	1/12

Compression Tee

Bronze



- FIP branch
- EPDM gaskets
- Pipe ends must be restrained
- Bronze coated brass bodies and nuts
- Maximum 125 PSI at temperatures up to 180°F
- For use on galvanized pipe and copper tubing (check sizes)

PART NO.	CTS	IPS	BRANCH	CTN/MSTR
C19050	1/2"	3/8"	1/2" FIP	1/12
C19051	3/4"	1/2"	1/2" FIP	1/96
C19075	3/4"	1/2"	3/4" FIP	1/12

Compression Tee

PVC



- For use on cold water lines only
- Ribbed body and nuts for gripping
- Fits both IPS and Schedule 40 pipe
- EPDM gaskets
- 150 PSI at 73°F
- Threaded branch

PART NO.	SIZE	CTN/MSTR
C17050	1/2"	1/25
C17075	3/4"	24/120
C17100	1"	15/60
C17125	1 1/4"	1/40
C17150	1 1/2"	1/20
C17200	2"	1/20

Economy Test Plug



- Molded rubber gasket
- Galvanized steel flanges
- Fits cast iron and plastic pipe

PART NO.	PIPE SIZE	CTN/MSTR
T31001	1 1/2"	24/192
T31002	2"	24/96
T31003	3"	24/48
T31004	4"	24/48
T31006	6"	4/16
T31000	Replacement wing nut	1/10

Combination Test Plug



Raised Head



Countersunk

- Test up to three floors at once
- Combination test plug and cleanout
- Fits Schedule 40 DWV pipe
- Positive sealing
- No metal parts to rust

Raised Head		
PART NO.	PIPE SIZE	CTN/MSTR
T34001	1 1/2"	1/392
T34002	2"	1/288
T34003	3"	1/200
T34004	4"	1/128
T34006	6"	1/54
T34008	8"	1/24
Countersunk		
PART NO.	PIPE SIZE	CTN/MSTR
T34012	2"	1/288
T34013	3"	1/200
T34014	4"	1/128

T-Cone Cleanout Repair Plugs



- Easily repairs damaged or corroded metal or plastic cleanout threads

PART NO.	PIPE SIZE	THREAD ID	CTN/MSTR
T34150	1 1/2"	1.780	1/50
T34200	2"	2.255	1/50
T34300	3"	3.375	1/50
T34350	3 1/2"	3.900	1/50
T34400	4"	4.336	1/50

"Plum-Tite" Mechanical Test Plugs



- Neoprene gasket
- Extra large wingnut
- Rust and corrosion proof
- High density plastic construction

PART NO.	SIZE	CTN/MSTR
T37001	1 1/2"	10/200
T37002	2"	10/150
T37003	3"	10/40
T37004	4"	10/40
T37006	6"	5/20
T37008	8"	5/10

Cast Iron Test Plug



- Maximum 10 PSI
- To test cast iron soil pipe drainage systems
- Cold water ONLY

PART NO.	PIPE SIZE	CTN QTY
T39002	2"	1
T39003	3"	1
T39004	4"	1
T39006	6"	1
T39008	8"	1
T39010	10"	1
T39012	12"	1

Flexible PVC Test Cap



- Reinforced top
- 5/16" hex screw with screwdriver slot
- Fits both cast iron and plastic pipe

PART NO.	PIPE SIZE	CTN/MSTR
T32001	1 1/2"	24/288
T32002	2"	24/288
T32003	3"	24/144
T32004	4"	1/50
T32006	6"	1/24
T32008	8"	1/16
T32011	1 1/2"	1/200
T32022	2"	1/100
T32033	3"	1/50
T32044	4"	1/50

PVC Dual Fit Test Cap



- Each cap fits two sizes of Schedule 40 pipe
- CARTON QUANTITIES ONLY

PART NO.	PIPE SIZE	CTN QTY
T33152	1 1/2" and 2"	100
T33304	3" and 4"	50

Slip-On Plastic Cap



- DWV protection cap in various colors
- Protects from debris during construction

PART NO.	SIZE	CTN/MSTR
T36150	1 1/2"	300
T36200	2"	200
T36300	3"	75
T36400	4"	1/45
T36600	6"	1/25

Techno Test Plug Cap



- Heavy duty PVC, high pressure tested over six stories
- Easily solvent cemented over end of DWV pipe
- Will not clog or go down pipe
- CARTON QUANTITIES ONLY

PART NO.	DESCRIPTION	CTN QTY
T35001	1 1/2" DWV	100
T35002	2" DWV	100
T35003	3" DWV	50
T35004	4" DWV	25

PVC Test Cap



- Easily solvent cemented over end of DWV pipe
- CARTON QUANTITIES ONLY

PART NO.	DESCRIPTION	CTN/MSTR
T35201	1 1/2" PVC Test Cap	100/1000
T35202	2" PVC Test Cap	100/1000
T35203	3" PVC Test Cap	50/250
T35204	4" PVC Test Cap	25/250
T35206	6" PVC Test Cap	1/100

Knockout Test Cap



- For use in plastic waste and drain pipe
- Disposable
- CARTON QUANTITIES ONLY

PART NO.	PIPE SIZE	CTN/MSTR
T33001	1 1/2"	100/5000
T33002	2"	100/1900
T33003	3"	50
T33004	4"	50/3600

Pneumatic Test Plug



- Manufactured in the USA
- All units smaller than 8" are supplied with chain and ring
- All units 8" or larger are supplied with a removable eye bolt
- For use with cast iron, PVC, ABS, copper, clay and concrete pipe

MADE IN THE USA

Regular					
PART NO.	NOM. PIPE SIZE	MAX AIR PRESSURE	MAX TEST PRESSURE	MAX HEAD	CTN/MSTR
T45150	1 1/4"-1 1/2"	40 PSI	5 PSI	30'	1/6
T45200	2"	40 PSI	5 PSI	30'	1/6
T45300	3"	35 PSI	5 PSI	30'	1/6
T45400	4"	30 PSI	5 PSI	30'	1/4
T45600	6"	25 PSI	5 PSI	30'	1
T45800	8"	25 PSI	15 PSI	40'	1
T45010	10"	25 PSI	15 PSI	40'	1
T45012	12"	25 PSI	15 PSI	40'	1

Long					
PART NO.	NOM. PIPE SIZE	MAX AIR PRESSURE	MAX TEST PRESSURE	MAX HEAD	CTN QTY
T46200	2"	45 PSI	5 PSI	30'	1
T46300	3"	35 PSI	5 PSI	30'	1
T46400	4"	30 PSI	5 PSI	30'	1

Pneumatic-Hydraulic Test Plug



- Uses either water or air
- Temperature range 30° - 200°F
- User safe; cannot be overinflated
- Individually tested for 24 hours to insure proper operation
- Using water, stack can be filled and plugged from same position

MADE IN THE USA

PART NO.	PIPE SIZE	MFG PART NO.	CTN/MSTR
T30002	1 1/4"-2"	WATP 2	1/6
T30034	3"-4"	WATP 3-4	1/10
T30046	4"-6"	WATP 4-6	1
T30068	5"-8"	WATP 6-8	1
T30102	10"-12"	WATP 10-12	1

Two Stage Long Test Plug



- Two stage deflation allows access pipe to remain sealed while water clears drain line

PART NO.	PIPE SIZE	MFG PART NO.	CTN QTY
T30203	2"-3"	DDO203	1
T30304	3"-4"	DDO304	1

Inflatable Tee Plug



- Threads directly into test tee
- Threads into both CI and plastic pipe
- Body is high quality natural rubber
- Top is made from high impact ABS plastic

Inflated Test Plug

PART NO.	DESCRIPTION	CTN/MSTR
T33200	2" Inflatable Tee Plug	6/36
T33300	3" Inflatable Tee Plug	1/6
T33400	4" Inflatable Tee Plug	1/6

Drain King®



- Insert in drain line opening
- Turn water on
- Automatically seals drain and powerful water pulses loosen and clear drain

PART NO.	PIPE SIZE	DK NO.	CTN/MSTR
D18501	1"-2"	D501	1/12
D18186	1 1/2"-3"	D186	12/144
D18034	3"-4"	H34	1/6
D18750	3"-6"	D750	1/6
D18850	6"-10"	D850	1
D18560	1"-2" with drain adapter	H560	1/5
D18340	1 1/2"-3" with 10" hose and faucet adapter	PE60	1/12
D18060	Drain Adapter	PE60	1/12

Plumbjet



- Attaches to garden hose
- All natural
- Environmentally safe

PART NO.	PIPE SIZE	DK NO.	CTN/MSTR
D18400	1"-2"	D501	10/60
D18401	1 1/2"-3"	D186	10/60
D18402	4"-6"	H34	10/40

Extension Hose



- For pneumatic test plug
- Can be used in tandem

PART NO.	SIZE	CTN QTY
T45002	2'	1
T45003	3'	1

Force Cup Plunger



- Supplied with handle
- Highest quality rubber plungers

PART NO.	DESCRIPTION	CTN QTY
D18001	5 1/2" diameter (red rubber)	12
D18002	6" professional style (black rubber)	12

Professional Force Cup Display



Cloghopper Display

- Supplied with handle
- Highest quality rubber plungers
- Attractive point of purchase display
- Display box contains 30 rubber plungers
- CARTON QUANTITIES ONLY

PART NO.	DESCRIPTION	CTN QTY
D18000	Rubber plungers and display box	30

Flexible PVC Saddle Fitting



Tee Pattern



Wye Pattern

- Provided with stainless steel clamp on inlet
- Includes stainless steel clamps on saddle to fit up to 12" clay pipe
- Extension clamps may be used for larger pipe sizes

Tee Pattern

PART NO.	DESCRIPTION	CTN/MSTR
S26001	4" plastic-12" clay saddle x 4" Sch.40 CI or SDR35 inlet	1
S26002	4" plastic - 6" clay saddle x 4" Sch.40 CI or SDR35 inlet	1
S26003	4" saddle blanket	1/6

Wye Pattern

PART NO.	DESCRIPTION	CTN QTY
S27001	4" plastic - 12" clay saddle x 4" Sch. 40 cast iron or SDR35 inlet	1
S27002	4" plastic - 6" clay saddle x 4" Sch. 40 cast iron or SDR35 inlet	1

Replacement Clamp

PART NO.	DESCRIPTION	CTN/MSTR
S26100	4"-12" gear clamp	1/100

Flexible Trap Drain Connector



PART NO.	DESCRIPTION	CTN/MSTR
T06001	Connects 1 1/4"-1 1/2" tubular to 1 1/4"-1 1/2" tubular	1/180
T06002	Connects 1" DWV or 1 1/2" CTS to 1 1/4"-1 1/2" tubular	1/100
T06003	Connects 1 1/2" DWV or CTS to 1 1/4"-1 1/2" tubular	1/100
T06004	Connects 2" DWV to 1 1/4"-1 1/2" tubular	1/100

Flexible Transition Coupling



T06320



T06400

- EPDM rubber
- UPC listed
- For use on PVC, DWV and CI pipe
- Stainless steel clamps and housing

PART NO.	DESCRIPTION	CTN/MSTR
T06025	1 1/4" PL + CI to PL + CI	1/300
T06050	1 1/2" PL + CI to PL + CI	1/150
T06200	2" PL + CI to PL + CI	1/105
T06250	2" x 1 1/2" PL + CI to PL + CI	1/105
T06300	3" PL + CI to PL + CI	1/60
T06320	3" x 2" PL + CI to PL + CI	1/80
T06400	4" PL + CI to PL + CI	1/36
T06430	4" x 3" PL + CI to PL + CI	1/44
T06600	6" PL + CI to PL + CI	1/12
T06640	6" x 4" PL + CI to PL + CI	1/15
T06800	8" PL + CI to PL + CI	1/6

Bore O-Ring



PART NO.	DESCRIPTION	CTN/MSTR
B12640	6" bore x 4" plastic or cast iron	1/60

Qwik Tee



PART NO.	DESCRIPTION	CTN/MSTR
T07150	1 1/2" x 1 1/2" x 1 1/2" tee	1/50
T07200	2" x 2" x 2" tee	1/20
T07300	3" x 3" x 3" tee	1/20
T07400	4" x 4" x 4" tee	1/6

Qwik Elbow



PART NO.	DESCRIPTION	CTN/MSTR
E10150	1 1/2" x 1 1/2" elbow	1/50
E10200	2" x 2" elbow	1/20
E10300	3" x 3" elbow	1/20
E10400	4" x 4" elbow	1/6

Bushing for Qwik Tees and Qwik Elbows



PART NO.	DESCRIPTION	CTN/MSTR
B12210	2" x 1 1/2" bushing	1/24
B12320	3" x 2" bushing	1/24
B12430	4" x 3" bushing	1/24

Hose Grip Clothes Washer Connector



- Fits 1 1/2" or 2" standpipe
- Fits 1" - 1 7/16" drain hose
- Securely holds drain hose in standpipe

PART NO.	DESCRIPTION	CTN/MSTR
D08001	Drain hose connector	1/100

Flexible Drain Trap



PART NO.	DESCRIPTION	CTN QTY
J01001	1 1/4" or 1 1/2" tubular trap j-bend	1/20

Washing Machine Boxes with Valves



- Long shank MIP valve
- White box with valve installed
- Combo 1 1/2" or 2" drain
- CARTON QUANTITIES ONLY

B05900

B05901

PART NO.	DESCRIPTION	CTN/MSTR
B05900	Offset drain	1/10
B05901	Center drain	1/10

Washing Machine Boxes with Hammer Arrestor



B05920

B05921

B05922



B05923

B05924

- 1/4 Turn valves or lever handle mixer valve

Dual Drain

PART NO.	DESCRIPTION	CTN/MSTR
B05920	1/4 Turn valve with Solder connection	1/10
B05921	1/4 Turn valve with CPVC connection	1/10
B05922	Single lever handle with Solder connection	1/10

Center Drain

PART NO.	DESCRIPTION	CTN/MSTR
B05923	1/4 Turn valve with Solder connection	1/10
B05924	1/4 Turn valve with CPVC connection	1/10

Replacement Frame

PART NO.	DESCRIPTION	CTN/MSTR
B05927	Replacement Frame for Washer Box	1/10
B05928	Replacement Frame for Icemaker Box	1/10

Icemaker Boxes with Hammer Arrestor



B05925



B05926

- 1/4 Turn valve

PART NO.	DESCRIPTION	CTN/MSTR
B05925	Icemaker box with Solder connection	1/10
B05926	Icemaker box with CPVC connection	1/10

Icemaker Boxes with Valves



- White box with valve installed
- CARTON QUANTITIES ONLY

PART NO.	DESCRIPTION	CTN/MSTR
B05910	Icemaker box with brass valve	1/10
B05911	Icemaker box with Flowguard all CPVC icemaker valve	1/10

Dishwasher Hose



- IAPMO/UPC listed; meets ANSI, AHAM-DWI specifications
- 5/8" connects dishwasher pump to airgap inlet or dishwasher tailpiece
- 7/8" connects airgap outlet to branch tailpiece or disposal
- EPDM material with single spiral reinforcement
- Resists kinking
- Marked per foot
- -40°F to +180°F

PART NO.	SIZE	WP	BURST PRESSURE	CTN QTY
D10625	5/8" ID x 50'	90	200	1
D10875	7/8" ID x 50'	70	100	1

Dishwasher Drain Connector



- Includes two worm gear clamps

PART NO.	DESCRIPTION	CTN/MSTR
D10001	Universal connector	50/200

Washing Machine Hose



Straight Female



With 90° Elbow

- For hot or cold use
- Bagged with washers
- Standard female hose threads
- Bursting pressure 800 lbs. per sq. inch
- 3/8" ID

PART NO.	LENGTH	CTN/MSTR
J04104	4'	1/12
J04105	5'	1/12
J04106	6'	1/12

Straight Female

PART NO.	LENGTH	CTN/MSTR
J04004	4'	1/12
J04005	5'	1/12
J04006	6'	1/12

Washing Machine Hose



- Industrial quality
- 1/2" ID EPDM rubber for hot and cold use
- Polyester yarn reinforcement
- 3/4" female hose ends
- Temp. rating -40°F to +190°F
- Stamped brass ends and crimps
- 200 PSI working pressure
- Bagged with washers

PART NO.	LENGTH	CTN/MSTR
J04204	4'	1/12
J04205	5'	1/12
J04206	6'	1/12

Mixer Hose



- High pressure hose; 12" arms
- Individually bagged

PART NO.	DESCRIPTION	CTN/MSTR
J04012	Mixer	1/12

Fit-All Drain Hose for Washing Machine



- Individually bagged
- 3 size step down 3/4", 7/8" and 1" for drain lines

PART NO.	SIZE	CTN/MSTR
J04016	5'	1/12

Washing Machine Drain Hose



PART NO.	SIZE	CTN QTY
D10900	1" x 50' roll	1

Washing Machine Pan



- 2 1/2" deep heavy gauge plastic pan
- CARTON QUANTITIES ONLY

PART NO.	DESCRIPTION	CTN/MSTR
J04250	29" x 31" with side mount drain	1/5

Dryer Vent Hood



- PVC hood
- Weather proof 12" aluminum extension
- Pre-punched mounting holes
- CARTON QUANTITIES ONLY

PART NO.	SIZE	CTN/MSTR
D04012	4"	1/12

Aluminum Vent Hood



- For clothes dryers or exhaust fans
- Complete with damper and flange plate

PART NO.	SIZE	CTN/MSTR
D04023	3"	1/12
D04024	4"	1/12

Louvered Dryer Vent Hood



- Includes hood, aluminum pipe and collar

PART NO.	DESCRIPTION	CTN/MSTR
D04025	4" white hood assembly	1/12
D04026	4" brown hood assembly	1/12

White Back Collar for Dryer Vent Kits



PART NO.	DESCRIPTION	CTN/MSTR
D04064	White back collar	1/6

Complete Dryer Vent Kit



- Kit includes hose (5' or 8'), vent and 2 plastic clamps
- Hood is waterproof plastic
- 5 3/4" square back plate
- 12" aluminum extension, pre-punched mounting holes

PART NO.	DESCRIPTION	CTN/MSTR
D04005	4" x 5'	1/10
D04008	4" x 8'	1/10
D04009	4" x 8' flex aluminum duct with louvered hood and two metal clamps	1/6

Clamp for Dryer Vent Kit



PART NO.	DESCRIPTION	CTN/MSTR
D04010	4" clamp only	1/10

Metal Clamp for Dryer Vent



- Heavy duty all metal design
- Excellent for use with metal ducting

PART NO.	SIZE	CTN/MSTR
D04015	3"	1/12
D04016	4"	1/12
D04017	5"	1/12
D04018	6"	1/12

Aluminum Elbow and Pipe



- All aluminum

PART NO.	DESCRIPTION	CTN/MSTR
D04013	3" x 90° swivel elbow	1/12
D04014	3" x 24" aluminum pipe	1/25
D04027	4" x 90° swivel elbow	1/12
D04028	4" x 24" aluminum pipe	1/25

Flexible Duct Connector Kit



- Connects flexible ducting
- Extends exhaust collar of clothes dryer

PART NO.	SIZE	CTN/MSTR
D04019	4"	1/6

Increaser/Decreaser



- Connects 3" to 4" ducting or 4" ducting to 3" exhaust collar

PART NO.	DESCRIPTION	CTN/MSTR
D04021	3"-4" plastic increaser/decreaser	1/6
D04022	4"-3" aluminum reducer	1/6
D04055	3"-4" aluminum increaser	1/6

Flexible Aluminum Ducting



- Ideal for exhausting clothes dryers
- Bendable to any configuration
- No fire or UL ratings

PART NO.	SIZE	CTN/MSTR
D04031	3" x 8'	1/14
D04032	4" x 8'	1/9
D04033	5" x 8'	1/6
D04034	6" x 8'	1/3
D04053	3" x 25'	1/10
D04054	4" x 25'	1/6

Proflex Aluminum Foil Ducting



- Flexible, fire resistant
- Will not support combustion
- Wire reinforced
- UL listed

PART NO.	SIZE	CTN/MSTR
D04058	4" x 5'	1/12
D04059	4" x 8'	1/12
D04060	4" x 50'	1

Flexible Aluminum Foil Ducting



- Ideal for exhausting clothes dryers and bathroom fans
- Will not support combustion
- No fire or UL ratings

PART NO.	SIZE	CTN/MSTR
D04056	4" x 25'	1
D04057	4" x 8'	1/12

Dryer Vent Hose



- Wire-reinforced vinyl

PART NO.	DESCRIPTION	CTN/MSTR
D04020	4" x 20' (boxed)	1/5
D04051	4" x 5' (bagged)	1/12

Dryer Vent Kit w/Louvered Hood



- Includes vinyl hose, aluminum pipe, collar, clamps and louvered hood

PART NO.	DESCRIPTION	CTN/MSTR
D04001	4" x 5' with white hood	1/10
D04002	4" x 5' with brown hood	1/10
D04003	4" x 8' with white hood	1/10
D04004	4" x 8' with brown hood	1/10

Bathroom Fan Vent Kit



- Contains the following part for 3" and 4" wall type exhaust fans: 4" x 5' flexible vinyl ducting, clamps, 4" louvered vent, 3"-4" foam increaser

PART NO.	DESCRIPTION	CTN/MSTR
D04035	Bathroom fan vent kit	1/10
D04050	4" x 50' (boxed)-vinyl hose only	1
D04062	3" x 50' (boxed)-vinyl hose only	1

Indoor Dryer Vent Kit



- Use on electric clothes dryers when outside venting is not possible
- Recirculates warm, moist air
- Specially designed lint reservoir

PART NO.	DESCRIPTION	CTN/MSTR
D04036	Indoor dryer vent kit	1/6

Domestic Pipe Wrap Tape



• CARTON QUANTITIES ONLY

Yellow			
PART NO.	SIZE	THICKNESS	CTN QTY
T16002	2" x 100'	12 mil.	24
T16004	4" x 100'	12 mil.	12
Black			
PART NO.	SIZE	THICKNESS	CTN QTY
T17002	2" x 100'	12 mil.	24
T17004	4" x 100'	12 mil.	12

Imported Pipe Wrap Tape



• UPC listed black tape with PVC backing
• CARTON QUANTITIES ONLY

PART NO.	SIZE	THICKNESS	CTN QTY
T17101	1" x 100'	10 mil.	48
T17102	2" x 100'	10 mil.	24
T17104	4" x 100'	10 mil.	12
T18201	1" x 100'	20 mil.	48
T18202	2" x 100'	20 mil.	24

Primer for Pipe Wrap Tape



• Maximizes tape performance
• Final step in preparing steel surfaces for taping
• Can more than double adhesion of corrosion tapes to cleaned steel
• CARTON QUANTITIES ONLY
• MOTOR FREIGHT ONLY / FLAMMABLE

PART NO.	SIZE	CTN QTY
T16100	Quart	12

Electrical Tape



• UL listed
• Individually wrapped
• Black vinyl
• CARTON QUANTITIES ONLY

PART NO.	SIZE	CTN/MSTR
T20030	3/4" x 60'	10/250

Slic-tite® High Density Thread Sealants



• Thickness 4 mils
• Provides a highly resistant seal on pipe threads for all types of service
• Non-toxic
• Permits easy disassembly, even after years of service
• Meets Mil. Spec T-27730A
• Sealing temperature: -450°F to 550°F (-268°C to 288°C)
• Pressures: to 2,000 PSI (136 BAR)



PART NO.	SIZE	CTN/MSTR
T19118	1/2" x 600"	12/36
T19119	3/4" x 600"	12/72

PTFE Thread Seal Tape



• Temperature range is 500°F to +650°F
• Withstands pressure up to 5000 PSI
• Meets U.S. government military specification MIL-T27730A
• Thickness 3 mil. plus

PART NO.	SIZE	CTN/MSTR
T19122	1/2" x 260"	100/500
T19125	1/2" x 520"	50/350
T19342	3/4" x 260"	50/350
T19345	3/4" x 520"	50/350

Thread Seal Tape Jar Display



• Meets U.S. MILSPEC T27730A
• Withstands pressure up to 5000 PSI
• Temperatures to +650°F
• Thickness 3 mil. plus

PART NO.	DESCRIPTION	CTN QTY
CJ1002	1/2" x 260" Teflon Tape	1

PTFE Yellow Gas Line Thread Seal Tape



• Temperature range is -450°F to +500°F
• Withstands pressure up to 5000 PSI
• Meets U.S. government military specification MIL-T27730A
• 0035 mil
• UL listed

PART NO.	SIZE	CTN/MSTR
T19222	1/2" x 260"	100/500

Duct Tape



• Premium grade, waterproof non-elastic reinforced cloth
• Pressure sensitive; vapor and flame resistant
• CARTON QUANTITIES ONLY

PART NO.	SIZE	THICKNESS	CTN QTY
T20020	2" x 60 yds (gray)	8.5 mil.	24
T20023	2" x 60 yds (black)	10 mil.	24

Box Sealing Tape



PART NO.	DESCRIPTION	CTN/MSTR
T20040	2" x 55 yds	36
T20041	2" x 110 yds	36
T20050	Dispenser	1/24

Self-Fusing Tape



• Silicone all purpose repair tape
• Water-tight seal for automotive, electrical, marine, plumbing and general-purpose applications
• Carded

PART NO.	DESCRIPTION	CTN/MSTR
T20200	20 mil x 1 x 16 self-fusing tape	1/100

Stretch Wrap

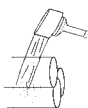

- Use instead of tape to bind packages or parts
- Protects products from dirt and moisture
- Can be used on palletted shipments or small orders
- Great for wrapping lengths of pipe
- CARTON QUANTITIES ONLY



PART NO.	SIZE	GAUGE	ROLLS/CTN
S51120	3" x 700'	120	18
S51080	3" x 1000'	80	18

Stretch Wrap Film and Dispenser



- Secures packages to pallets
- Reduces lost packages
- Retards moisture
- Lowers handling costs
- Wrapping is priced per carton - no broken cartons

PART NO.	DESCRIPTION	CTN QTY
S51001	80 gauge wrap 18" x 1500'	1
S51002	Hand dispenser	1

Pipe Sleeving



- Underground sleeving protects against lime reaction in concrete
- Allows expansion and contraction of pipe, minimizing stress
- Individually boxed; color-coded (red for hot, blue for cold)
- UPC approved and IAPMO listed

PART NO.	PIPE SIZE	THICKNESS	COLOR	LENGTH	CTN/MSTR
S22001	1/2"-1"	6 mil	Red	200'	1/20
S22002	1/2"-1"	6 mil	Blue	200'	1/20
S22003	1/2"-1"	10 mil	Red	100'	1/20
S22004	1/2"-1"	10 mil	Blue	100'	1/20
S22005	1/2"-1"	25 mil	Red	100'	1/20
S22006	1/2"-1"	25 mil	Blue	100'	1/20

Water Resistant Sand Cloth



- Dispenser box
- Water resistant aluminum oxide
- 120 grit abrasive cloth for cleaning pipe and fittings

PART NO.	SIZE	CTN/MSTR
C25000	1 1/2" x 2 yds	1/50
C25001	1 1/2" x 5 yds	1/50
C25002	1 1/2" x 10 yds	1/50
C25003	1 1/2" x 25 yds	1/25

Open Mesh



- Dispenser box
- 100% waterproof
- Polyester on both sides
- 180 grit with large holes for aggressive sanding
- Can be exposed to water and solvents indefinitely without breakdown

PART NO.	SIZE	CTN/MSTR
C25010	1 1/2" x 5 yds	1/50
C25011	1 1/2" x 10 yds	1/50

Flexible Open Mesh



- Dispenser box
- 100% waterproof
- Polyester on both sides
- 180 grit
- Smaller holes for finer sanding

PART NO.	SIZE	CTN/MSTR
C25012	1 1/2" x 5 yds	1/50
C25013	1 1/2" x 10 yds	1/50

Waterproof Aluminum Oxide



- Dispenser box
- 100% waterproof
- Wet cut
- 120 grit

PART NO.	SIZE	CTN/MSTR
C25020	1 1/2" x 5 yds	1/50
C25021	1 1/2" x 10 yds	1/50
C25022	1 1/2" x 25 yds	1/25

SEAMLESS RUBBER

Pipe Insulation

Flexible Closed Cell Insulation

C



DESCRIPTION

Seamless Rubber Pipe Insulation is an environmentally friendly, CFC-free, flexible elastomeric thermal insulation.

APPLICATIONS

Seamless Rubber Pipe Insulation is used to retard heat gain and prevent condensation or frost formation on refrigerant lines, cold water plumbing, and chilled water systems. It also retards heat flow for hot water plumbing, liquid heating, dual temperature piping, and many solar systems.

Seamless Rubber is recommended for applications ranging from -70°F to 220° F (-57° C to 104° C). The expanded closed cell structure makes Seamless Rubber an efficient insulator and an effective moisture vapor retarder.

Due to its unique microwave curing process, Seamless Rubber has a very tough skin which withstands tearing, rough handling, and severe environmental conditions, and yet is quite flexible for easy installation.

Seamless Rubber has superior cold weather flexibility.

INSTALLATION

With a factory-applied coating of talc on the smooth inner surface, Seamless Rubber slides easily over pipe or tubing for quick installation. When applied to existing lines, tubing is slit lengthwise and snapped into place. (Slitting can be done on the job with a sharp knife. All seams and butt joints should be sealed with Seamless Rubber Contact Adhesive, making sure both surfaces to be joined are coated with adhesive.

OUTDOOR APPLICATIONS

Outdoor applications require UV Protective Coating. For best appearance, two coats are recommended.

UNDERGROUND

For buried lines above the water table, use a clean fill such as sand (3"-5" layer) to protect Seamless Rubber before backfilling. It is recommended that materials to be buried are properly sealed at all seams and butt joints with Contact Adhesive. For optimum performance, the lines should be encased in a conduit to protect them from problems associated with ground water.

RESISTANCE TO MOISTURE VAPOR FLOW

The closed-cell structure of Seamless Rubber effectively retards the flow of moisture vapor, and is considered a low transmittance vapor retarder. For most applications, Seamless Rubber needs no additional protection. Additional vapor barrier protection may be necessary for Seamless Rubber when

installed on low temperature surfaces or where it is exposed to continuous high humidity.

FLAME AND SMOKE RATING

Seamless Rubber Pipe Insulation in wall thicknesses of 1" (25 mm) and below has a flame spread rating of 25 or less and a smoke development rating of 50 or less as tested by ASTM E 84 Method of Testing entitled: "Surface Burning Characteristics of Building Materials."

Numerical flammability ratings alone may not define the performance of products under actual fire conditions. They are provided only for us in the selection of products to meet limits specified, when compared to a known standard.

SPECIFICATION COMPLIANCE

ASTM C 534 Type 1 (Tubing)
ASTM D 1056-91-2C1
MEA 186-86-M Vol. IV (New York City)
USDA Requirements

UL 94-5V Flammability Classification (Recognition No. E55475)
Complies with requirements of CAN/ULC S102-M88
ASTM E 84 1" 25/50-tested according to UL 723 and NFPA 255

Meets requirements of NFPA 90A Sect. 2.3.3 for Supplementary Materials for Air Distribution Systems

NFPA No. 101 Class A Rating
Meets requirements of UL 181 sections 11.0 and 16.0

MIL-P-15280, For T (Tubing)

C

PHYSICAL PROPERTIES		SEAMLESS RUBBER INSULATION	TEST METHODS
Thermal Conductivity (K)	90° F (32° C) Mean Temp	.282 (.041)	ASTM C 177
BTU · in/hr-Ft2 · °F (W/mK)	75° F (24° C) Mean Temp	.277 (.040)	ASTM C 177
	50° F (10° C) Mean Temp	.270 (.039)	ASTM C 177
Operating Temperature Range	Upper	200° F (104° C)	
Flexible to -100° F (-73° C)	Lower	-70° F (-57° C)	
Water Vapor Permeability Dry Cup. Perm-In		.10	ASTM E 96
Water Absorption % weight gain		5%	ASTM D 1056
Ozone Resistant		Pass	ASTM D 1171
Chemical/Solvent Resistance		Good	
Mildew Resistance/Air Erosion		Pass	UL 181

THICKNESS RECOMMENDATIONS* - TO CONTROL CONDENSATION								
PIPE SIZE	LINE TEMP		LINE TEMP		LINE TEMP		LINE TEMP	
	50° F	10° C	35° F	2° C	0° F	-18° C	-20° F	-29° C
Normal Conditions (Max 85°F, 29°C - 70% R.H.)								
3/8" ID thru 1 3/8" ID	3/8"	10 mm	1/2"	13 mm	3/4"	19 mm	1"	25 mm
Over 1 3/8" thru 3" IPS	3/8"	10 mm	1/2"	13 mm	1"	25 mm	1"	25 mm
Over 3" IPS thru 4" IPS**	1/2"	13 mm	1/2"	13 mm	1"	25 mm	1 1/4"	32 mm
Over 4" IPS	1/2"	13 mm	3/4"	19 mm	1"	25 mm	1 1/4"	32 mm
Mild Conditions (Max 80°F, 26°C - 50% R.H.)								
3/8" ID thru 2 1/8" ID	3/8"	10 mm	3/8"	10 mm	1/2"	13 mm	1/2"	13 mm
Over 2 1/8" thru 3" IPS	3/8"	10 mm	3/8"	10 mm	1/2"	13 mm	3/4"	19 mm
Over 3" IPS thru 4" IPS**	1/2"	13 mm	1/2"	13 mm	3/4"	19 mm	3/4"	19 mm
Over 4" IPS	1/2"	13 mm	1/2"	13 mm	3/4"	19 mm	3/4"	19 mm
Severe Conditions (Max 90°F, 32°C - 80% R.H.)								
3/8" ID thru 1 1/8" ID	3/4"	19 mm	3/4"	19 mm	1 1/4"	32 mm	1 1/4"	32 mm
Over 1 1/8" ID thru 4" IPS	3/4"	19 mm	1"	25 mm	1 1/2"	38 mm	1 1/2"	38 mm
Over 4" IPS	3/4"	19 mm	1 1/4"	32 mm	1 3/4"	44 mm	2"	50 mm

Seamless Rubber in thickness notes within the specified temperature ranges will prevent condensation on indoor piping under design conditions defined below. Thickness recommendations above 1" can be sleeved to achieve thickness desired.

Normal: Maximum severity of indoor conditions seldom exceed 85° F (29° C) and 70% R.H. in United States.

Mild: Typical conditions are most air-conditioned spaces and arid climates.

Severe: Generally found in areas which excessive moisture is introduced or in poorly ventilated areas where the temperature may be depressed below the ambient.

Under conditions of high humidity, additional thickness of insulation may be required.

**Available: Nom. 1/2" or Nom. 3/4" thickness only

SEAMLESS RUBBER "R" VALUES PER SQUARE FOOT					
Pipe OD or Nominal Insulation ID		R Value 3/8" (10 mm) Wall	R Value 1/2" (13 mm) Wall	R Value 3/4" (19 mm) Wall	R Value 1" (25 mm) Wall
3/8"	10 mm	2.3	3.1	4.7	-
1/2"	13 mm	2.2	2.9	4.7	7.6
5/8"	16 mm	2.1	2.7	4.6	7.1
3/4"	19 mm	2.0	2.6	4.6	6.7
7/8"	22 mm	1.9	2.7	4.6	6.5
1 1/8"	29 mm	1.8	2.6	4.6	5.1
1 3/8"	35 mm	1.8	2.7	4.4	5.8
1 1/2" IPS	-	2.0	2.6	4.3	5.5
1 5/8"	41 mm	2.1	2.7	4.3	5.5
2 1/8"	54 mm	1.9	2.6	4.0	5.2
2" IPS	-	2.0	2.7	4.1	5.2
2 1/2" IPS	64 mm	1.9	2.6	3.9	5.0
2 5/8"	67 mm	2.0	2.7	4.0	5.1
3 1/8"	79 mm	1.9	2.5	3.8	4.9
3" IPS	-	2.0	2.8	3.9	5.0
3 5/8"	92 mm	-	2.6	3.7	-
4 1/8"	105 mm	-	2.6	3.7	-
4" IPS	-	-	2.8	3.9	-
5" IPS	-	1.9	2.6	3.9	-
6" IPS	-	-	2.4	3.6	-
8" IPS	-	-	2.4	3.6	-

Note: "R" factors were calculated from using the K factor of .277 (75°F, 24°C mean temp) and nominal wall thickness in each case. Lower operating temperatures will result in improved R values.

Seamless Rubber Pipe Insulation



- Environmentally friendly
- 4 Wall thicknesses: 3/8", 1/2", 3/4" and 1"
- Sizes range from 3/8" ID to 4" IPS
- Sizes not listed are special order. Allow two weeks for delivery.
- CFC-free
- Color - Black with blue ink
- Easy installation, flexible
- CARTON QUANTITIES ONLY

3/8" Wall Thickness			
PART NO.	COPPER OD	IPS/PVC	FT/BOX
I60025	1/4"	-	630'
I60038	3/8"	-	612'
I60050	1/2"	1/4"	432'
I60058	5/8"	3/8"	378'
I60075	3/4"	-	342'
I60078	7/8"	1/2"	288'
I60118	1 1/8"	-	216'
I60138	1 3/8"	-	168'
I60158	1 5/8"	1 1/4"	150'
I60200	-	1 1/2"	120'
I60218	2 1/8"	-	96'
I60250	-	2"	84'
I60258	2 5/8"	-	72'
I60300	-	2 1/2"	60'
I60318	3 1/8"	-	60'
I60350	-	3"	48'
1/2" Wall Thickness			
PART NO.	COPPER OD	IPS/PVC	FT/BOX
I61038	3/8"	-	456'
I61050	1/2"	1/4"	360'
I61058	5/8"	3/8"	324'
I61075	3/4"	-	270'
I61078	7/8"	1/2"	228'
I61118	1 1/8"	-	156'
I61138	1 3/8"	-	120'
I61158	1 5/8"	1 1/4"	114'
I61200	-	1 1/2"	114'
I61218	2 1/8"	-	102'
I61250	-	2"	66'
I61258	2 5/8"	-	60'
I61300	-	2 1/2"	48'
I61318	3 1/8"	-	48'
I61350	-	3"	36'
I61358	3 5/8"	-	36'
I61418	4 1/8"	-	24'
I61450	-	4"	24'

Seamless Rubber Pipe Insulation



- Environmentally friendly
- 4 Wall thicknesses: 3/8", 1/2", 3/4" and 1"
- Sizes range from 3/8" ID to 4" IPS
- Sizes not listed are special order. Allow two weeks for delivery.
- CFC-free
- Color - Black with blue ink
- Easy installation, flexible
- CARTON QUANTITIES ONLY

3/4" Wall Thickness			
PART NO.	COPPER OD	IPS/PVC	FT/BOX
I62038	3/8"	-	294'
I62050	1/2"	1/4"	228'
I62058	5/8"	3/8"	180'
I62075	3/4"	-	144'
I62078	7/8"	1/2"	126'
I62118	1 1/8"	-	90'
I62138	1 3/8"	-	78'
I62158	1 5/8"	1 1/4"	72'
I62200	-	1 1/2"	66'
I62218	2 1/8"	-	60'
I62250	-	2"	48'
I62258	2 5/8"	-	42'
I62300	-	2 1/2"	36'
I62318	3 1/8"	-	36'
I62350	-	3"	30'
I62358	3 5/8"	-	30'
I62418	4 1/8"	-	24'
I62450	-	4"	24'
1" Wall Thickness			
PART NO.	COPPER OD	IPS/PVC	FT/BOX
I63058	5/8"	3/8"	108'
I63075	3/4"	-	108'
I63078	7/8"	1/2"	90'
I63118	1 1/8"	-	66'
I63138	1 3/8"	-	60'
I63158	1 5/8"	1 1/2"	54'
I63200	-	1 1/2"	42'
I63218	2 1/8"	-	42'
I63250	-	2"	36'
I63258	2 5/8"	-	36'
I63300	-	2 1/2"	36'
I63318	3 1/8"	-	30'
I63350	-	3"	30'
I63358	3 5/8"	-	30'

Double Stick Rubber Pipe Insulation



- Environmentally friendly
- 4 Wall thicknesses: 3/8", 1/2", 3/4" and 1"
- Sizes range from 3/8" ID to 4" IPS
- Split with adhesive on both sides
- CFC-free
- Color - Black with blue ink
- Easy installation, flexible
- CARTON QUANTITIES ONLY

3/8" Wall Thickness

PART NO.	COPPER OD/IPS	FT/BOX
I80038	3/8"	570'
I80050	1/2"	402'
I80058	5/8"	348'
I80034	3/4"	318'
I80078	7/8"	288'
I80118	1 1/8"	216'
I80138	1 3/8"	150'
I80150	1 1/2" IPS	120'
I80158	1 5/8"	132'
I80200	2" IPS	78'
I80218	2 1/8"	78'
I80250	2 1/2" IPS	60'
I80258	2 5/8"	72'
I80318	3 1/8"	60'

1/2" Wall Thickness

PART NO.	COPPER OD/IPS	FT/BOX
I81038	3/8"	420'
I81050	1/2"	312'
I81058	5/8"	312'
I81034	3/4"	270'
I81078	7/8"	216'
I81118	1 1/8"	150'
I81138	1 3/8"	120'
I81150	1 1/2" IPS	108'
I81158	1 5/8"	108'
I81200	2" IPS	60'
I81218	2 1/8"	60'
I81250	2 1/2" IPS	48'
I81258	2 5/8"	60'
I81300	3" IPS	36'
I81318	3 1/8"	48'
I81358	3 5/8"	36'
I81400	4" IPS	24'
I81418	4 1/8"	24'

Double Stick Rubber Pipe Insulation



- Environmentally friendly
- 4 Wall thicknesses: 3/8", 1/2", 3/4" and 1"
- Sizes range from 3/8" ID to 4" IPS
- Split with adhesive on both sides
- CFC-free
- Color - Black with blue ink
- Easy installation, flexible
- CARTON QUANTITIES ONLY

3/4" Wall Thickness

PART NO.	COPPER OD/IPS	FT/BOX
I82038	3/8"	258'
I82050	1/2"	192'
I82058	5/8"	180'
I82034	3/4"	120'
I82078	7/8"	126'
I82118	1 1/8"	90'
I82138	1 3/8"	78'
I82150	1 1/2" IPS	66'
I82158	1 5/8"	72'
I82200	2" IPS	48'
I82218	2 1/8"	60'
I82250	2 1/2" IPS	36'
I82258	2 5/8"	42'
I82300	3" IPS	30'
I82318	3 1/8"	36'
I82358	3 5/8"	30'
I82400	4" IPS	24'
I82418	4 1/8"	24'

1" Wall Thickness

PART NO.	COPPER OD/IPS	FT/BOX
I83058	5/8"	108'
I83034	3/4"	78'
I83078	7/8"	78'
I83118	1 1/8"	66'
I83138	1 3/8"	60'
I83150	1 1/2" IPS	42'
I83158	1 5/8"	42'
I83200	2" IPS	36'
I83218	2 1/8"	42'
I83250	2 1/2" IPS	36'
I83258	2 5/8"	36'
I83300	3" IPS	30'
I83318	3 1/8"	30'
I83358	3 5/8"	30'
I83418	4 1/8"	18'

CLOSED CELL Pipe Insulation



DESCRIPTION

Closed Cell Pipe Insulation is a flexible and easy-to-apply tubing product available in Semi-Slit and Self-Sealing styles. These chemically inert pipe insulations are specially formulated to retard heat gain and their closed-cell structures allow them to function as efficient insulators. The Self-Sealing version has yellow self-seal release liner that is both easy to see and peel.

APPLICATIONS

To reduce unwanted heat loss or heat gain, control condensation, decrease plumbing noise and maximize energy savings. They can be used on hot and cold water lines, refrigeration lines, air conditioning lines; line set tubing, condenser coils, and connection and distribution lines.

Closed Cell Pipe Insulation has low thermal conductivity and a very low water vapor transmission rate. This low density product demonstrates excellent thermal, physical and chemical resistant properties, and has a broad service temperature range between -90° F and 180° F (-68° C and 82° C). It can be installed in commercial, industrial, and residential insulation projects.

INSTALLATION

Closed Cell Pipe Insulation is installed by sliding the stick over pipe or tubing. For existing lines, the insulation should be slit lengthwise and fitted over the pipe. When in place, make sure all seams are adhered with contact adhesive and pressed together to form a seal. The Self-Sealing version does not require adhesive. Fittings can be fabricated from miter-cut tubular sections. Closed Cell Pipe Insulation is easily cut with a sharp knife.

OUTDOOR APPLICATIONS

Outdoor applications require a protective coating (high quality exterior acrylic latex paint) for optimum performance. For best appearance, two coats are recommended.

UNDERGROUND

For buried lines above the water table, use a clean fill such as sand (3"-5" layer) to protect Closed Cell Pipe Insulation before backfilling. It is recommended that all materials to be buried are properly sealed at all seams and butt joints with Contact Adhesive. For optimum performance, the lines should be encased in conduit to protect them from problems associated with ground water.

RESISTANCE TO MOISTURE VAPOR FLOW

The closed-cell structure effectively retards the flow of moisture vapor, and is considered a low transmittance vapor retarder. For most applications, Closed Cell Pipe Insulation needs no additional protection.

Additional vapor barrier protection may be necessary for Closed Cell Pipe Insulation when installed on low temperature surfaces or where it is exposed to continuous high humidity.

FLAME AND SMOKE RATING

Closed Cell Pipe Insulation in wall thicknesses of 1" (25mm) and below has a flame spread rating of 25 or less and a smoke development rating of 50 or less as tested by ASTM E 84; CAN/ULC-S102.2-M88 Method of Testing entitled: "Surface Burning Characteristics of Building Materials."

Numerical flammability ratings alone may not define the performance of products under actual fire conditions. They are provided only for use in the selection of products to meet limits specified, when compared to a known standard.

SPECIFICATION COMPLIANCE

Complies with requirements of:

ASTM E 84; CAN/ULC S102.2

ASTM D 1622

ASTM D 1171

ASTM C 177 or C518

ASTM E 96

PHYSICAL DATA	PROPERTIES	TEST METHODS
Material	Closed Cell Polyolefin	-
Color	Charcoal	-
Upper Use Limit	180°F (82°C) constant	-
Lower Use Limit	-90°F (-68°C)	-
Density	1.5 lbs/ft ³	ASTM D 1622
Ozone Resistant	Good	ASTM D 1171
Thermal Conductivity (K)	at 75° F (24°C) Mean Temp	ASTM C 177 or C 518
BTU-in/hr-ft ² - F° (W/m-K)	0.230 (0.033)	-
Water Absorption	0.02% by Volume	ASTM E 96
Flame Speed	Less than 25	ASTM E 84; CAN/ULC-S102.2-M88
Smoke Classification	Less than 50	ASTM E 84; CAN/ULC-S102.2-M88

THICKNESS RECOMMENDATIONS* - TO CONTROL CONDENSATION								
PIPE SIZE	LINE TEMP		LINE TEMP		LINE TEMP		LINE TEMP	
	50° F	10° C	35° F	2° C	0° F	-18° C	-20° F	-29° C
Normal Conditions (Max 85°F, 29°C - 70% R.H.)								
3/8" ID thru 1 3/8" ID	3/8"	10 mm	1/2"	13 mm	3/4"	19 mm	1"	25 mm
Over 1 3/8" thru 3" IPS	3/8"	10 mm	1/2"	13 mm	1"	25 mm	1"	25 mm
Over 3" IPS thru 4" IPS**	3/8"	10 mm	1/2"	13 mm	1"	25 mm	1"	25 mm
Over 4" IPS	1/2"	13 mm	3/4"	19 mm	1"	25 mm	1 1/4"	32 mm
Mild Conditions (Max 80°F, 26°C - 50% R.H.)								
3/8" ID thru 2 1/8" ID	3/8"	10 mm	3/8"	10 mm	3/8"	10 mm	1/2"	13 mm
Over 2 1/8" thru 3" IPS	3/8"	10 mm	3/8"	10 mm	3/8"	10 mm	1/2"	13 mm
Over 3" IPS thru 4" IPS**	3/8"	10 mm	3/8"	10 mm	1/2"	13 mm	3/4"	19 mm
Over 4" IPS	3/8"	10 mm	1/2"	13 mm	1/2"	13 mm	3/4"	19 mm
Severe Conditions (Max 90°F, 32°C - 80% R.H.)								
3/8" ID thru 1 1/8" ID	3/4"	19 mm	3/4"	19 mm	1 1/4"	32 mm	1 1/4"	32 mm
Over 1 1/8" ID thru 4" IPS	3/4"	19 mm	1"	25 mm	1 1/2"	38 mm	1 1/2"	38 mm
Over 4" IPS	3/4"	19 mm	1"	25 mm	1 1/2"	38 mm	2"	50 mm

Closed Cell Pipe Insulation in thickness notes within the specified temperature ranges will prevent condensation on indoor piping under design conditions defined below. Thickness recommendations above 1" can be sleeved to achieve thickness desired.

Normal: Maximum severity of indoor conditions seldom exceed 85° F (29° C) and 70% R.H. in United States.

Mild: Typical conditions are most air-conditioned spaces and arid climates.

Severe: Generally found in areas which excessive moisture is introduced or in poorly ventilated areas where the temperature may be depressed below the ambient. Under conditions of high humidity, additional thickness of insulation may be required.

**Available: Nom. 1/2" or Nom. 3/4" thickness only

CLOSED CELL "R" VALUES PER SQUARE FOOT					
Pipe OD or Nominal Insulation ID		R Value 3/8" (10 mm) Wall	R Value 1/2" (13 mm) Wall	R Value 3/4" (19 mm) Wall	R Value 1" (25 mm) Wall
3/8"	10 mm	2.687	3.844	-	-
1/2"	13 mm	2.490	3.582	6.027	-
5/8"	16 mm	2.357	3.375	5.653	8.189
3/4"	19 mm	2.680	3.223	5.374	7.767
7/8"	22 mm	2.187	3.107	5.155	7.435
1 1/8"	29 mm	2.082	4.835	4.835	6.941
1 3/8"	35 mm	2.011	2.822	4.610	6.588
1 5/8"	41 mm	1.959	2.737	4.420	6.323
1 7/8"	-	1.920	2.672	4.313	6.115
2 1/8"	54 mm	1.889	2.620	4.209	5.948
2 3/8"	-	1.864	2.578	4.124	5.810
2 5/8"	67 mm	1.844	2.544	4.053	5.695
2 7/8"	-	1.827	2.514	3.993	5.596
3 1/8"	79 mm	1.812	2.490	3.942	5.512
3 1/2"	-	-	2.459	3.877	5.404
3 5/8"	92 mm	-	2.449	-	5.373
4"	105 mm	-	2.425	-	-
4 1/8"	-	-	2.418	-	5.264
4 1/2"	-	-	2.399	-	5.196

Note: "R" factors were calculated from using the K factor of .230 (75°F, 24°C mean temp) and nominal wall thickness is each case. Lower operating temperatures will result in improved R values.

Semi-Slit Pipe Insulation



- 100% closed cell polyethylene
- UPS shippable cartons - CARTON QUANTITIES ONLY
- For outdoor use, paint with a high quality exterior acrylic latex paint

SPECIFICATIONS:
 Density: 1.5 lbs./cubic foot; Mold growth: None;
 Temperature Range: -90° to 180°F; Flame/Smoke:
 25/50; Water vapor permeability: less than .02
 inches; Ozone resistance: Good

3/8" Wall Thickness

PART NO.	NOMINAL ID	R VALUES	CTS	IPS	FT/BOX
I50058	5/8"	2.357	1/2"	3/8"	408'
I50075	3/4"	2.680	5/8"	-	360'
I50078	7/8"	2.187	3/4"	1/2"	300'
I50118	1 1/8"	2.082	1"	3/4"	240'
I50138	1 3/8"	2.011	1 1/4"	1"	192'
I50158	1 5/8"	1.959	1 1/2"	1 1/4"	132'
I50178	2"	1.920	-	1 1/2"	108'
I50218	2 1/8"	1.889	2"	-	90'
I50238	2 3/8"	1.864	-	2"	90'
I50258	2 5/8"	1.844	2 1/2"	-	72'

1/2" Wall Thickness

PART NO.	NOMINAL ID	R VALUES	CTS	IPS	FT/BOX
I51058	5/8"	3.375	1/2"	3/8"	306'
I51078	7/8"	3.107	3/4"	1/2"	240'
I51118	1 1/8"	4.835	1"	3/4"	180'
I51138	1 3/8"	2.822	1 1/4"	1"	150'
I51158	1 5/8"	2.737	1 1/2"	1 1/4"	120'
I51178	2"	2.672	-	1 1/2"	90'
I51218	2 1/8"	2.620	2"	-	84'
I51238	2 3/8"	2.578	-	2"	66'
I51258	2 5/8"	2.544	2 1/2"	-	60'

3/4" Wall Thickness

PART NO.	NOMINAL ID	R VALUES	CTS	IPS	FT/BOX
I54050	1/2"	6.027	3/8"	1/4"	204'
I54058	5/8"	5.653	1/2"	3/8"	180'
I54075	3/4"	5.374	5/8"	1/2"	168'
I54078	7/8"	5.155	3/4"	-	156'
I54118	1 1/8"	4.835	1"	-	102'
I54138	1 3/8"	4.610	1 1/4"	1"	90'
I54158	1 5/8"	4.420	1 1/2"	1 1/4"	84'
I54178	2"	4.313	-	1 1/2"	66'
I54218	2 1/8"	4.209	2"	-	54'
I54258	2 5/8"	4.053	2 1/2"	-	48'

1" Wall Thickness

PART NO.	NOMINAL ID	R VALUES	CTS	IPS	FT/BOX
I55058	5/8"	8.189	1/2"	3/8"	108'
I55075	3/4"	7.767	5/8"	1/2"	102'
I55078	7/8"	7.435	3/4"	-	90'
I55118	1 1/8"	6.941	1"	-	90'
I55138	1 3/8"	6.588	1 1/4"	1"	72'
I55158	1 5/8"	6.323	1 1/2"	1 1/4"	60'
I55178	2"	6.115	-	1 1/2"	54'
I55218	2 1/8"	5.948	2"	-	48'
I55258	2 5/8"	5.695	2 1/2"	-	42'

Self-Sealing Pipe Insulation



- 100% closed cell polyethylene
- UPS shippable cartons - CARTON QUANTITIES ONLY
- Complete seal on hot or cold pipe
- Two strips of self-adhesive seal easily at any length

SPECIFICATIONS:
 Density: 1.5 lbs./cubic foot; Mold growth: None;
 Temperature Range: -90° to 180°F; Flame/Smoke:
 25/50; Water vapor permeability: less than .02
 inches; Ozone resistance: Good

3/8" Wall Thickness

PART NO.	NOMINAL ID	R VALUES	CTS	IPS	FT/BOX
I52058	5/8"	2.357	1/2"	3/8"	408'
I52034	3/4"	2.680	5/8"	-	360'
I52078	7/8"	2.187	3/4"	1/2"	300'
I52118	1 1/8"	2.082	1"	3/4"	240'
I52138	1 3/8"	2.011	1 1/4"	1"	192'
I52158	1 5/8"	1.959	1 1/2"	1 1/4"	132'
I52178	2"	1.920	-	1 1/2"	108'
I52218	2 1/8"	1.889	2"	-	90'
I52238	2 3/8"	1.864	-	2"	90'
I52258	2 5/8"	1.844	2 1/2"	-	72'
I52318	3 1/8"	1.812	3"	-	54'
I52358	3 5/8"	-	-	-	42'

1/2" Wall Thickness

PART NO.	NOMINAL ID	R VALUES	CTS	IPS	FT/BOX
I53038	3/8"	3.844	-	-	-
I53050	1/2"	3.582	-	-	-
I53058	5/8"	3.375	1/2"	3/8"	306'
I53075	3/4"	3.223	3/4"	1/2"	270'
I53078	7/8"	3.107	3/4"	1/2"	240'
I53118	1 1/8"	4.835	1"	3/4"	180'
I53138	1 3/8"	2.822	1 1/4"	1"	150'
I53158	1 5/8"	2.737	1 1/2"	1 1/4"	120'
I53178	2"	2.672	-	1 1/2"	90'
I53218	2 1/8"	2.620	2"	-	84'
I53238	2 3/8"	2.578	-	2"	66'
I53258	2 5/8"	2.544	2 1/2"	-	60'
I53318	3 1/8"	2.490	3"	-	48'
I53312	3 1/2"	2.459	-	3"	42'
I53358	3 5/8"	2.449	3 1/2"	-	42'
I53418	4 1/8"	2.418	4"	-	30'
I53412	4 1/2"	2.399	-	4"	30'

3/4" Wall Thickness

PART NO.	NOMINAL ID	R VALUES	CTS	IPS	FT/BOX
I56058	5/8"	5.653	1/2"	3/8"	180'
I56075	3/4"	5.374	5/8"	1/2"	168'
I56078	7/8"	5.155	3/4"	1/2"	156'
I56118	1 1/8"	4.835	1"	3/4"	102'
I56138	1 3/8"	4.610	1 1/4"	1"	90'
I56158	1 5/8"	4.420	1 1/2"	1 1/4"	84'
I56218	2 1/8"	4.209	2"	-	54'

1" Wall Thickness

PART NO.	NOMINAL ID	R VALUES	CTS	IPS	FT/BOX
I57058	5/8"	8.189	1/2"	3/8"	108'
I57078	7/8"	7.435	3/4"	1/2"	90'
I57115	3/4"	7.767	5/8"	-	102'
I57118	1 1/8"	6.941	1"	-	90'
I57138	1 3/8"	6.588	1 1/4"	1"	72'
I57158	1 5/8"	6.323	1 1/2"	1 1/4"	60'
I57178	2"	6.115	-	1 1/2"	54'
I57218	2 1/8"	5.948	2"	-	56'
I57238	2 3/8"	5.810	-	2"	42'
I57258	2 5/8"	5.695	2 1/2"	-	36'

Poly Pipe Insulation Tees & Elbows



- 100% closed cell polyethylene
- UPS shippable cartons - CARTON QUANTITIES ONLY
- Complete seal on hot or cold pipe
- Two strips of self-adhesive to seal easily



SPECIFICATIONS:
 Density: 1.5 lbs./cubic foot; Mold growth: None;
 Temperature Range: -90° to 180°F; Flame/Smoke:
 25/50; Water vapor permeability: less than .02
 inches; Ozone resistance: Good

PART NO.	DESCRIPTION	WALL THICKNESS	CTN/MSTR
I59050	1/2" Tee	3/8"	1/16
I59075	3/4" Tee	3/8"	1/12
I59100	1" Tee	3/8"	1/12
I59125	1-1/4" Tee	3/8"	1/8
I59150	1/2" Elbow	3/8"	1/32
I59175	3/4" Elbow	3/8"	1/20
I59200	1" Elbow	3/8"	1/16
I59225	1-1/4" Elbow	3/8"	1/12

Insulation Contact Adhesive



- Brush top cans
- For use with rubber insulation only
- CARTON QUANTITIES ONLY
- MOTOR FREIGHT ONLY/FLAMMABLE

PART NO.	DESCRIPTION	CTN QTY
IA1050	Fast Tack 1/2 pint	48
IA1100	Fast Tack 1 pint	24
IA2050	Slow Tack 1/2 pint	48
IA2100	Slow Tack 1 pint	24

Insulation Protective Coating



PART NO.	SIZE	CTN QTY
IPC004	1 gallon	4

Insulation Tape



PART NO.	DESCRIPTION	CTN QTY
INT001	1/8" x 2" x 30' cork tape	12
INT002	1/8" x 2" x 30' tape	12

Flanged Dielectric Union



- Temperature range: 180°F at 200 PSI
- Maximum temperature 200°F

PART NO.	FIP x COPPER SWEAT	CTN/MSTR
D06250	2-1/2" x 2-1/2"	1/5
D06300	3" x 3"	1/5
D06400	4" x 4"	1/5

Thermal Expansion Tanks



- Designed for the protection of potable hot water systems
- Install between the backflow preventer and the water heater
- Specifications:
 Factory pre-charge: 40psi
 System Connection: 304 Stainless Steel
 Diaphragm: Butyl Rubber
 Liner Material: Food Grade Polypropylene
 Max. Operating Temp.: 200°F
 Max. Operating Pressure: 150psi

PART NO.	DESCRIPTION	CTN. QTY.	PALLET QTY.
R15202	2 gallon tank	1	150
R15204	4-1/2 gallon tank	1	80

Dual Port Self Cleaning Thermal Expansion Tank



- Designed for the protection of potable hot water systems
- Install between the backflow preventer and the water heater
- Specifications:
 Factory pre-charge: 15psi
 System Connection: 304 Stainless Steel
 Diaphragm: Butyl Rubber
 Liner Material: Food Grade Polypropylene
 Max. Operating Temp.: 200°F
 Max. Operating Pressure: 150psi

PART NO.	DESCRIPTION	CTN. QTY.	PALLET QTY.
R15206	2 gallon tank	1	150

Dielectric Union - Lead Free



Female x Sweat



Male x Sweat

- Prevents electrolysis or galvanic action when connecting dissimilar metals
- Residential or commercial use
- Zinc plated forged steel
- Solder ends conform to ANSI B16.19
- EPDM washer, ABS fiber sleeve
- Threads conform to ANSI B2.1
- Pressure rated at 250 PSI at 180°F

Female x Sweat			
PART NO.	FIP x COPPER SWEAT	OD	CTN/MSTR
D06050	1/2" x 1/2"	5/8"	24/144
D06075	3/4" x 3/4"	7/8"	12/144
D06100	1" x 1"	1-1/8"	12/120
D06125	1-1/4" x 1-1/4"	1-3/8"	6/48
D06150	1-1/2" x 1-1/2"	1-5/8"	6/48
D06200	2" x 2"	2-1/8"	6/24

Reducing			
PART NO.	FIP x COPPER SWEAT	OD	CTN/MSTR
D06350	3/4" x 1/2"	5/8"	24/144

Male x Sweat			
PART NO.	MIP x COPPER SWEAT	OD	CTN/MSTR
D06005	1/2" x 1/2"	7/8"	12/144
D06750	3/4" x 3/4"	7/8"	24/96

Reducing			
PART NO.	MIP x COPPER SWEAT	OD	CTN/MSTR
D06755	3/4" x 1/2"	5/8"	24/144

Universal Copper Thermocouple



- All copper with brass fittings
- Adaptable to 5 different pilot valves
- Kit includes 2 clips and nuts
- Individually carded

PART NO.	LENGTH	CTN/MSTR
J36118	18"	10/100
J36124	24"	10/100
J36130	30"	1/10
J36136	36"	1/10
J36148	48"	1/10

Gasket and Insert for Dielectric Union



Insert



Gasket

- For water
- 200°F temperature rating

Insert		
PART NO.	DESCRIPTION	CTN QTY
D06800	1/2" insert	25
D06801	3/4" insert	25
D06802	1" insert	25
D06803	1-1/4" insert	25
D06804	1-1/2" insert	25
D06805	2" insert	25
Gasket		
PART NO.	DESCRIPTION	CTN QTY
D06850	1/2" gasket	25
D06875	3/4" gasket (EPDM rubber)	25
D06900	1" gasket	25
D06901	1 1/4" gasket	25
D06902	1 1/2" gasket	25
D06903	2" gasket	25

Dielectric Nipple



- 180° maximum temperature
- Prevents corrosion, lime and scale buildup
- Adds years of life to any water system
- For use on water heaters, dishwashers, water filtration systems
- Electroplated steel casing with non-corrosion thermoplastic lining

PART NO.	SIZE	CTN/MSTR
D06753	3/4" MIP x 3" length	1/200
D06450	1/2" MIP x 3" length	1/350
D06500	1" MIP x 3" length	1/100
D06510	1" MIP x 4" length	1/100
D06525	1 -1/4" MIP x 4" length	1/30
D06550	1-1/2" MIP x 4" length	1/30
D06600	2" MIP x 4" length	1/30
D06650	2-1/2" MIP x 6" length	1/20
D06700	3" MIP x 6" length	1/12

PlumBite Push On Water Heater Connector



- Leak-Free, Tool-Free & Solvent Free
- Approved for behind-the-wall installation
- Fittings may be reused if necessary
- Internal PEX Tube insert provided for Perfect PEX connections
- For use with hot and cold potable water
- Operating temperature 0°F to 200°F, 200 PSI

PART NO.	SIZE	CTN/MSTR
C76605	1/2" Push Fitting x 3/4" FIP x 12"	1/80
C76606	1/2" Push Fitting x 3/4" FIP x 15"	1/80
C76607	1/2" Push Fitting x 3/4" FIP x 18"	1/80
C76608	1/2" Push Fitting x 3/4" FIP x 24"	1/80
C76612	3/4" Push Fitting x 3/4" FIP x 12"	1/80
C76613	3/4" Push Fitting x 3/4" FIP x 15"	1/80
C76614	3/4" Push Fitting x 3/4" FIP x 18"	1/80
C76615	3/4" Push Fitting x 3/4" FIP x 24"	1/80
C76616	1/2" Push Valve x 3/4" FIP x 18"	1/80
C76617	3/4" Push Valve x 3/4" FIP x 18"	1/80

Corrugated Water Heater Connector

- Corrugated for easy flex on water heaters and softeners
- Includes rubber washers

Copper



PART NO.	FPT x LENGTH	CTN/MSTR
J34712	3/4" x 12"	1/50
J34715	3/4" x 15"	1/50
J34718	3/4" x 18"	1/50
J34724	3/4" x 24"	1/50



PART NO.	FIP x SWT x LENGTH	CTN/MSTR
J35712	3/4" x 3/4" x 12"	25/50
J35715	3/4" x 3/4" x 15"	25/50
J35718	3/4" x 3/4" x 18"	25/50
J35724	3/4" x 3/4" x 24"	25/50



PART NO.	FIP x MIP x LENGTH	CTN/MSTR
J36712	3/4" x 3/4" x 12"	1/25
J36715	3/4" x 3/4" x 15"	1/25
J36718	3/4" x 3/4" x 18"	1/25
J36724	3/4" x 3/4" x 24"	1/25

Stainless Steel



PART NO.	MIP x FIP x LENGTH	CTN/MSTR
J38712	3/4" x 3/4" x 12"	25/50
J38715	3/4" x 3/4" x 15"	25/50
J38718	3/4" x 3/4" x 18"	25/50
J38724	3/4" x 3/4" x 24"	25/50



PART NO.	FIP x FIP x LENGTH	CTN/MSTR
J39712	3/4" x 3/4" x 12"	25/50
J39715	3/4" x 3/4" x 15"	25/50
J39718	3/4" x 3/4" x 18"	25/50
J39724	3/4" x 3/4" x 24"	25/50

Braided Stainless Steel Water Heater Connector

- UPC listed
- LEAD FREE



PART NO.	FIP x LENGTH	CTN/MSTR
S04350	3/4" x 12"	10/40
S04351	3/4" x 18"	10/40
S04352	3/4" x 24"	10/40



PART NO.	FIP x COMP x LENGTH	CTN/MSTR
S04353	3/4" x 3/4" x 12"	10/40
S04354	3/4" x 3/4" x 18"	10/40
S04355	3/4" x 3/4" x 24"	10/40



PART NO.	FIP x MIP x LENGTH	CTN/MSTR
S04356	3/4" x 3/4" x 12"	10/40
S04357	3/4" x 3/4" x 18"	10/40
S04358	3/4" x 3/4" x 24"	10/40



PART NO.	MIP x COMP x LENGTH	CTN/MSTR
S04359	3/4" x 3/4" x 12"	10/40
S04360	3/4" x 3/4" x 18"	10/50
S04361	3/4" x 3/4" x 24"	10/50

Water Heater Stand



- Galvanized
- Snap-in legs
- Easy to assemble
- Rating approval at 2,000 lbs. static weight

PART NO.	DESCRIPTION	CTN/MSTR
J36200	18" square x 17" high water heater stand	1/4

Water Heater Stand



- No assembly required
- 3/4 tubular steel construction
- Non-rust paint
- 800 lbs. static weight

PART NO.	DESCRIPTION	CTN QTY
J36300	25 1/2" x 17" high water heater stand	1
J36250	28" x 17" high water heater stand	1

Stand-rite Water Heater Stand



- Lab tested
- Meets UPC requirements
- Heavy duty
- Corrosion resistant
- 14 gauge galvanized steel
- Top 21.5" x 21.5"
- Rated up to 650 pounds
- For water heaters up to 65 gallons
- Includes mounting clips for securing to wall/floor
- Quick assembly

PART NO.	DESCRIPTION	CTN QTY
J36400	Water heater stand	1

Water Heater Safety Pan



- Supplied with 1" hookup adapter for any drain type (J34-800)
- 2 1/2" depth
- High impact plastic
- Southern Building Code and natural gas approved
- CARTON QUANTITIES ONLY

PART NO.	BOTTOM ID	TOP ID	CTN/MSTR
J36018	19"	20 1/2"	1/20
J36022	22"	22 1/2"	1/20
J36024	24"	25 1/2"	1/20
J36026	26"	27 1/2"	1/10
J36030	30"	31 1/2"	1/5

Galvanized Hot Water Heater Pans



- 24 gauge
- Flared sides
- 1" fitting (J34-800)

PART NO.	DESCRIPTION	CTN QTY
J37022	22" x 22" x 4"	1
J37024	24" x 24" x 4"	1
J37026	26" x 26" x 4"	1
J37028	28" x 28" x 4"	1
J37030	30" x 30" x 4"	1

Water Heater Pan



Seamless Galvanized Corner



- Seamless galvanized water heater pans are holded not welded
- 1" drain connector included (J34-800)
- One piece stamped aluminum .032 mil (20 gauge)
- Aluminum pans comply with SBCCI, sec. 1213.7

Round Aluminum

PART NO.	DESCRIPTION	CTN/MSTR
J38020	20" round water heater pan	1/10
J38022	22" round water heater pan	1/10
J38024	24" round water heater pan	1/10
J38026	26" round water heater pan	1/10
J38030	30" round water heater pan	1/5

Seamless Galvanized

PART NO.	DESCRIPTION	CTN QTY
J39019	19" seamless water heater pan	1
J39023	23" seamless water heater pan	1
J39027	27" seamless water heater pan	1
J39030	30" seamless water heater pan	1

Water Heater Pan Adapter



- 1" PVC
- Washer and locknut
- Fits all Jones Stephens pans

PART NO.	DESCRIPTION	CTN/MSTR
J34800	1" Adapter	1/25

Run-Off Tube



- UL listed
- For water heaters
- Electroplated fittings
- 230°F temperature rating
- Hand tighten to T and P valve

PART NO.	DESCRIPTION	CTN/MSTR
J34975	3/4" NPT x 60" side mount	1/100
J34980	3/4" NPT top mount	1/25
J34970	3/4" NPT x 60" side mount	1/15

Gas Testing Equipment



- Large 4" face
- Class 1A gauge
- 5 lb. gas test gauge/15 lb. gas test gauge
- 1/10 # increments
- Inches of mercury scale
- External set hand
- Bellows design
- 1/4 NPT connection
- Gauge meets all requirements of the City of Houston code Word 94-108, Section 1204.3.2, revised January 18, 2001
- ALL SALES FINAL; NO WARRANTY; NO RETURN

PART NO.	DESCRIPTION	CTN/MSTR
G60055	15 lb. gas test gauge only	1/20
G65055	15 lb. gauge, body and valve-complete	1/20
G60005	5 lb. gas test gauge only	1/20
G64055	5 lb. gauge, body and valve-complete	1/20

2 1/2" Face Liquid Filled Pressure Gauge



- +/- 1.5% accuracy
- Glycerin filled for use where vibration or pressure pulsation occur
- -50 to 150°F operating temperature
- 1/4" NPT bottom connection
- Polished 304 stainless steel case with vent plug

PART NO.	DESCRIPTION	CTN/MSTR
J40553	0-30 PSI	1/50
J40554	0-60 PSI	1/50
J40555	0-100 PSI	1/50
J40556	0-200 PSI	1/50
J40557	0-300 PSI	1/50

Pressure Gauge



- 1/4" MIP brass lower connection
- Applicable with air, water, oil and gas - anything which does not attack brass
- Not for use on oxygen service
- Individually boxed
- Steel case
- Shatterproof face
- Class 2.5-2% accuracy

2" Face		
PART NO.	PRESSURE RATING	CTN/MSTR
G60015	15 PSI	1/100
G60030	30 PSI	1/100
G60060	60 PSI	1/100
G60100	100 PSI	1/100
G60160	160 PSI	1/100
G60200	200 PSI	1/100
G60300	300 PSI	1/100

2 1/2" Face		
PART NO.	PRESSURE RATING	CTN/MSTR
G61015	15 PSI	1/100
G61030	30 PSI	1/60
G61060	60 PSI	1/100
G61100	100 PSI	1/100
G61160	160 PSI	1/100
G61200	200 PSI	1/100
G61300	300 PSI	1/100

3 1/2" Face		
PART NO.	PRESSURE RATING	CTN/MSTR
G62030	30 PSI	1/50
G62060	60 PSI	1/50
G62100	100 PSI	1/50
G62200	200 PSI	1/50
G62300	300 PSI	1/50

Pigtail Syphon



- For use with gauges on steam line
- 1/4" MPT x 1/4" MPT
- Steel construction

PART NO.	DESCRIPTION	CTN/MSTR
G60000	Straight	20/200
G60001	90° Angle	10/200

Water Test Gauge



- Individually boxed
- 3/4" brass hose connection
- Steel case with 2 1/2" shatterproof face

PART NO.	DESCRIPTION	CTN/MSTR
J66300	300 PSI	1/50
J66301	300 PSI with indicator	1/50

Silcock/Water or Gas Test Gauge Assembly



- Brass air valve
- Individually boxed
- Adapts to 3/4" male garden hose or 3/4" MIP
- Comes with garden hose adapter
- Steel case with 2" shatterproof face

PART NO.	DESCRIPTION	CTN/MSTR
G64101	200 PSI	1/50

5 Pound Gas Test Gauge



- 1/4" NPT
- 2 1/2" diaphragm
- 1/10 # increments
- For building code inspection

PART NO.	DESCRIPTION	CTN/MSTR
G61005	5 lb. gas test gauge	1/100

Gas Test Gauge



- 2" steel case gauge on 15 lb.
- 5 lb. is marked in 1/10 lb. increments
- 15 lbs. is marked in 1/10 lb. increments
- Plated body with 3/4" FIP inlet
- 2 1/2" diaphragm on 5 lb.
- Adapts to 3/4" MPT
- Brass air valve
- Individually boxed

PART NO.	DESCRIPTION	CTN/MSTR
G64015	15 lb. gas test gauge assembly	1/50
G64005	5 lb. gas test gauge assembly	1/50

Test Gauge Assembly

Bell Type



PART NO.	DESCRIPTION	CTN/MSTR
G66015	13# x 3/4" FIP	1/50
G66030	30# x 3/4" FIP	1/50
G66060	60# x 3/4" FIP	1/50
G66100	100# x 3/4" FIP	1/24
G67015	15# x 1" FIP	1/50
G67030	30# x 1" FIP	1/50
G67060	60# x 1" FIP	1/50
G67100	100# x 1" FIP	1/100
G66000	3/4" Bell body (less air valve)	1/100
G66002	3/4" Bell body (with air valve)	1/100
G67000	1" Bell body (less air valve)	1/59
G67002	1" Bell body (with air valve)	1/80

Gas Test Assembly



- 4" face and pressure snubber
- Regulates air to an even flow
- Over pressurization will void the warranty
- Protects the diaphragm from compressed air damage
- Class 1A gauge

PART NO.	DESCRIPTION	CTN QTY
G64155	5 lb. Test Assembly	1
G65155	15 lb. Test Assembly	1

Gas Test Gauge Assembly



- Adapts to 3/4" MPT
- Steel case with 2" shatterproof face
- Plated body with 3/4" FIP inlet
- Brass air valve
- Individually boxed

PART NO.	DESCRIPTION	CTN/MSTR
G64030	30 PSI	1/50
G64060	60 PSI	1/50
G64100	100 PSI	1/50
G64160	160 PSI	1/50
G64200	200 PSI	1/50
G64333	300 PSI	1/50
G64000	1/4" air valve and cap	50/300
G64001	Gas test body only	1/100
G64002	1/8" air valve and cap	500/1000
G64020	Gas test body and air valve assembly	1/100

Tridicator



- 0-55 PSI
- 70°F to 250°F temperature range

PART NO.	DESCRIPTION	CTN/MSTR
J40550	2 1/2" face angle 2 1/4" stem (1/4" NPT)	1/50
J40551	2 1/2" face angle 2 1/2" stem (1/4" NPT)	1/50
J40558	2 1/2" face angle 1" stem (1/4" NPT)	1/50
J40560	3 1/2" face angle 2 3/4" stem (1/2" NPT)	1/50

Vacuum Gauge



- 1/4" brass lower connection
- -30 to 0 inch Hg
- Black steel case with bronze internals

PART NO.	DESCRIPTION	CTN/MSTR
G63001	Vacuum gauge (2" face)	1/100

Pressure Snubber



- Use on lines with noticeable pressure changes/oscillations
- Bronze body and core
- 1000 PSI maximum

PART NO.	DESCRIPTION	CTN/MSTR
G64300	1/4" NPT for air or gas	1/700
G64301	1/4" NPT for oil, steam or water	1/200

Needle Valve for Pressure Gauge



- 1/4" NPT
- Brass body, seat, stem and handle
- 300°F maximum temperature
- Female x female
- Teflon packing
- 2000 PSI

PART NO.	DESCRIPTION	CTN/MSTR
G64004	1/4" needle valve	1/125

Hot Water/Refrigerant Line Thermometer



- Straight or angle pattern
- Steel or brass well
- 40°-280°F x 5°F (5-120°C x 2°C)
- 1/2" NPT; 1" stem

PART NO.	DESCRIPTION	DIM (A)	DIM (B)	CTN/MSTR
J40500	Straight pattern steel well	1"	1/2" NPT	1/50
J40501	Straight pattern brass well	1"	1/2" NPT	1/50
J40502	Angle pattern steel well	1"	1/2" NPT	1/50
J40503	Angle pattern brass well	1"	1/2" NPT	1/50

Dial Thermometer



- 2 1/2" face
- 5° increments
- Dual scale: 40°-240°/0°-120°C
- Brass wells/removable thermometers
- Thermometers are supplied with wells

PART NO.	DESCRIPTION	CTN/MSTR
J40702	3/4" SWT connection	1/50
J40703	1/2" MIP connection	1/100
J40704	3/4" SWT well	1/100
J40705	1/2" MIP well	1/100

Weksler Industrial Multi-Angle Thermometer

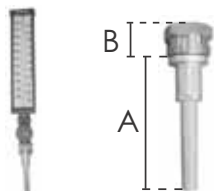

- No well provided; order wells separately
- 9" scale, red-reading mercury tubes
- Molded cyclac case with glass window
- Adjustable to any angle
- Accurate to +/- one scale division
- Must have well

PART NO.	DESCRIPTION	DIM (A)	DIM (B)	CTN/MSTR
J40505	Hot water 30°-240°F	3 1/2" stem	1" NPSM	1/50
J40506	Cold water 0°-120°F	3 1/2" stem	1" NPSM	1/25
J40510	Standard brass well	2 1/2" stem	3/4" NPT	1/100
J40511	Extended well	1 3/4" stem	3/4" NPT	1/100

Bi-Metal Dial Thermometer

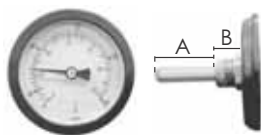

- For commercial or home heating systems
- 1/2" NPT
- 20°-240°F temperature range
- 3" dial in steel case
- Angle has back connection; straight has bottom connection

PART NO.	DESCRIPTION	DIM (A)	DIM (B)	CTN/MSTR
J40561	Angle outlet with brass well	1 1/8" stem	1/2" NPT	1/50
J40562	Straight outlet with brass well	2 3/8" stem	1/2" NPT	1/50

Brass Wells



- Solid brass construction
- 1 1/2" stem
- 1/2" MPT x 1/4" FPT threads

PART NO.	DESCRIPTION	CTN/MSTR
J40563	Brass wells for J40-562	1/200

Pocket Test Thermometer



- 2% accuracy for hot and cold
- Pocket clip on sheath; 5" stem

PART NO.	DESCRIPTION	CTN/MSTR
J40700	Cold thermometer (-40° to 160°F)	1/80
J40701	Hot thermometer (0° to 220°F)	1/80

Natural Polyethylene Tubing



- Non-toxic, 100% virgin material
- 100' coils in dispenser box
- FDA
- -40°F to +135°F

PART NO.	OD	ID	PSI	WALL	CTN QTY
T25250	1/4"	.170"	120	.040	100'
T25312	5/16"	.187"	150	.040	100'
T25375	3/8"	.250"	125	.062	100'
T25500	1/2"	.375"	95	.062	100'
T25625	5/8"	.500"	75	.500	100'

Clear Vinyl Tubing



- 75 duro clear
- -5°F to +125°F
- Self-dispensing cartons
- FDA

PART NO.	OD	ID	WALL	WPPSI	CTN QTY
T26124	3/16"	1/8"	1/32"	50	100'
T26125	1/4"	1/8"	1/16"	80	100'
T26186	1/4"	3/16"	1/32"	40	100'
T26187	5/16"	3/16"	1/16"	60	100'
T26250	3/8"	1/4"	1/16"	55	100'
T26252	1/2"	1/4"	1/8"	90	100'
T26312	7/16"	5/16"	1/16"	50	100'
T26313	1/2"	5/16"	3/32"	60	100'
T26375	1/2"	3/8"	1/16"	45	100'
T26376	9/16"	3/8"	3/32"	55	100'
T26377	5/8"	3/8"	1/8"	65	100'
T26498	5/8"	1/2"	1/16"	30	100'
T26500	3/4"	1/2"	1/8"	45	100'
T26626	3/4"	5/8"	1/16"	30	100'
T26625	7/8"	5/8"	1/8"	40	100'
T26750	1"	3/4"	1/8"	35	100'
T26875	1 1/8"	7/8"	1/8"	30	50'
T26000	1 1/4"	1"	1/8"	28	50'

Soft Aluminum Tubing



- 50' coils
- Alloy 3003-0, ASTM B-483

PART NO.	OD	WALL	CTN/MSTR
T27125	1/8"	.025	1/10
T27188	3/16"	.028	1/10
T27250	1/4"	.032	1/10
T27313	5/16"	.035	1/10
T27375	3/8"	.035	1/10
T27438	7/16"	.035	1/10
T27500	1/2"	.035	1/10
T27625	5/8"	.035	1/10

Stud Protectors and Plate



- Protects piping and wiring from nails
- CARTON QUANTITIES ONLY

PART NO.	SIZE	GAUGE	CTN QTY
S33001	1 1/2" x 6"	18	100
S33002	1 1/2" x 3"	18	100
S33003	5" x 8" (not self nailed)	16	50
S33005	1 1/2" x 6"	16	100
S33006	1 1/2" x 5"	18	100
S33010	1 1/2" x 6"	22	100
S33011	1 1/2" x 3"	22	100
S33012	3 1/2" x 6" (not self nailed)	16	25
S33014	3 1/2" x 6" (self nailed)	16	25

Interlocking Stud Guard



- CARTON QUANTITIES ONLY

PART NO.	SIZE	GAUGE	CTN QTY
S33004	1 1/2" x 6"	20	100
S33007	1 1/2" x 6"	16	100
S33016	3 1/2" x 6"	16	25

Stud Shoe



- 18 gauge galvanized
- Four nail holes on each side
- Pipe opening accommodates 2" IPS or smaller pipe
- Stud/joist reinforcement when drilling or notching for pipe runs
- CARTON QUANTITIES ONLY

PART NO.	DESCRIPTION	CTN QTY
S33021	Single stud shoe	50
S33022	Double stud shoe	25
S33023	Triple stud shoe	10

Stud Guard



- 6 Holes
- 2 Nailers
- Protects pipes
- CARTON QUANTITIES ONLY

PART NO.	SIZE	GAUGE	CTN QTY
S33013	5" x 8"	16	25

Stud Guard



- CARTON QUANTITIES ONLY

PART NO.	SIZE	GAUGE	CTN QTY
S33318	3 1/2" x 18"	16	25

Stud Guard



- 20 Holes
- CARTON QUANTITIES ONLY

PART NO.	SIZE	GAUGE	CTN QTY
S33518	5" x 18"	16	25

Stud Guard



S180032



S16006



S163566

- CARTON QUANTITIES ONLY

Self Nailing Stud Guard with 2 Holes Centered

PART NO.	SIZE	GAUGE	CTN QTY
S180032	1 1/2" x 3"	18	200

2 Hole Stud Guard

PART NO.	SIZE	GAUGE	CTN QTY
S16006	1 1/2" x 6"	16	100

6 Hole Stud Guard

PART NO.	SIZE	GAUGE	CTN QTY
S163566	3 1/2" x 6"	16	25

Self Nailed Stud Guard

PART NO.	SIZE	GAUGE	CTN QTY
S16009	1 1/2" x 9"	16	100
S16012	1 1/2" x 12"	16	100
S16018	1 1/2" x 18"	16	50
S16024	1 1/2" x 24"	16	25
S20012	1 1/2" x 12"	20	100
S20009	1 1/2" x 9"	20	100
S16005	1 1/2" x 5"	16	100
S16003	1 1/2" x 3"	16	100

F.H.A. Strap - Galvanized Steel



- Tie plates
- CARTON QUANTITIES ONLY

PART NO.	SIZE	GAUGE	CTN QTY
F12009	1 1/2" x 9"	12	50
F18009	1 1/2" x 9"	18	100
F12012	1 1/2" x 12"	12	50
F18012	1 1/2" x 12"	18	100
F12018	1 1/2" x 18"	12	50
F18018	1 1/2" x 18"	18	100
F12024	1 1/2" x 24"	12	50
F18024	1 1/2" x 24"	18	100

F.H.A. Strap

 • CARTON QUANTITIES ONLY

PART NO.	SIZE	GAUGE	CTN QTY
F18309	3" x 9"	18	50
F18312	3" x 12"	18	50
F18318	3" x 18"	18	50
F18324	3" x 24"	18	50

F.H.A. Strap



• CARTON QUANTITIES ONLY

One Hole in Each Corner

PART NO.	SIZE	GAUGE	CTN QTY
F165181	5" x 18"	16	15

2 Holes

PART NO.	SIZE	GAUGE	CTN QTY
F180032	1 1/2" x 3"	18	200

3 Holes Vertically Aligned

PART NO.	SIZE	GAUGE	CTN QTY
F160123	1 1/2" x 12"	16	50
F160183	1 1/2" x 18"	16	50
F160243	1 1/2" x 24"	16	50
F160363	3" x 6"	16	50
F160393	3" x 9"	16	50
F160063	1 1/2" x 6"	16	50
F160093	1 1/2" x 9"	16	50



Standard F.H.A. with 4 Offset Holes

PART NO.	SIZE	GAUGE	CTN QTY
F14012	1 1/2" x 12"	14	50
F16012	1 1/2" x 12"	16	50
F160184	1 1/2" x 18"	16	50
F160094	1 1/2" x 9"	16	50

Standard F.H.A. with 6 Offset Holes

PART NO.	SIZE	GAUGE	CTN QTY
F160126	1 1/2" x 12"	16	50
F16016	1 1/2" x 16"	16	50
F160186	1 1/2" x 18"	16	50
F160246	1 1/2" x 24"	16	50
F163186	3" x 18"	16	50
F163246	3" x 24"	16	50
F165186	5" x 18"	16	15

Galvanized Bracket

- For use on sinks, lavatories and toilets on 16" center studs
- For use with 1/2" and 3/4" CPVC; 1/2", 3/4" and 1" copper or PEX
- 1 3/8" keyed holes, 20" long
- Use with B00016, B00017, B00018 and B00013
- CARTON QUANTITIES ONLY

PART NO.	HR #	DESCRIPTION	CTN QTY
B00001	103-18	1/2" - 1" x 20"	50

Flat Copper Plated Bracket



- For use on sinks, lavatories or other fixtures
- Use for 1/2" copper pipe
- CARTON QUANTITIES ONLY

PART NO.	HR #	DESCRIPTION	CTN QTY
B00003	101-18	1/2" x 20"	50
B00021	101-26	1/2" x 26"	50

Flat Copper Plated Bracket



- For use on water heater connections
- Use for 3/4" and 1" copper pipe
- CARTON QUANTITIES ONLY

PART NO.	HR #	DESCRIPTION	CTN QTY
B00004	102-18	3/4" - 1" x 20"	50



Flat Copper Plated Bracket



- For use on 1/2", 3/4" or 1" copper pipe
- CARTON QUANTITIES ONLY

PART NO.	HR #	DESCRIPTION	CTN QTY
B00005	107-18	1/2" - 1" x 20"	50

Flat Copper Plated Bracket

- Copper-Bonded™ steel
- For support of 1/2" and 3/4" pipes on 4" or 8" centers
- Positions copper water supplies for sinks, water closets, and other fixtures
- 25 lb. load rating
- CARTON QUANTITIES ONLY

PART NO.	HR #	DESCRIPTION	CTN QTY
B00025	150-20	1/2" - 3/4" x 20"	50

Carrier Bracket



- Copper plated
- Secures 1" stub out at 11 1/2" above the rim
- CARTON QUANTITIES ONLY

PART NO.	HR #	DESCRIPTION	CTN QTY
B00022	114-C	Carrier Bracket	6
B00023	114-R	Carrier Bracket	6

Holdrite Bracket



- 150 lb. load capacity
- Can attach to stud or directly to wall

PART NO.	HR #	DESCRIPTION	CTN QTY
B00024	V2	Pipe Bracket	25

Extruded Hole Copper Plated Bracket



- For use on 1/2", 3/4" or 1" copper pipe
- Extruded holes
- CARTON QUANTITIES ONLY

PART NO.	HR #	DESCRIPTION	CTN QTY
B00006	108-20	1/2" - 1" x 20"	50
B00019	108-26	1/2" - 1" x 26"	50

Extruded Notches Copper Plated Bracket



- For use on 1/2", 3/4" or 1" copper pipe
- Extruded holes
- CARTON QUANTITIES ONLY

PART NO.	HR #	DESCRIPTION	CTN QTY
B00007	140	1/2" - 3/4" x 20"	50

Galvanized Lockright Pipe Bracket-CPVC



- For use on sinks or lavatories using CPVC
- 20 gauge galvanized steel with 1" holes on 2" centers
- Use with B00-014 and B00-015
- CARTON QUANTITIES ONLY

PART NO.	HR #	DESCRIPTION	CTN QTY
B00008	601-20	1/2" - 3/4" x 20"	50

Galvanized Lockright Bracket



- CARTON QUANTITIES ONLY

PART NO.	HR #	DESCRIPTION	CTN QTY
B00020	601-26	1/2" - 3/4" x 26"	50

Bracket for Water Closet-Copper Clad

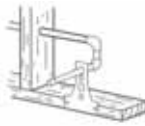

- For use on 1/2" copper pipe
- For use with water closets or hose bibbs
- CARTON QUANTITIES ONLY

PART NO.	HR #	DESCRIPTION	CTN QTY
B00002	109-N-6	1/2"	50

Galvanized L Bracket



- For use with PEX on overhead and side runs
- Use with B00-013, B00-016, B00-017 and B00-018 inserts
- CARTON QUANTITIES ONLY

PART NO.	HR #	DESCRIPTION	CTN QTY
B00009	709L	Bracket with 1 3/8" keyed holes-PEX	50

Galvanized Bracket



- For use on lavatories and toilets
- Use with B00-013, B00-016, B00-017 and B00-018 inserts
- CARTON QUANTITIES ONLY

PART NO.	HR #	DESCRIPTION	CTN QTY
B00010	709	Bracket with 1 3/8" keyed holes-PEX	50

18 Gauge Galvanized Bracket-CPVC



- For use on residential toilets or hose bibbs
- Use with B00-014 or B00-015 inserts
- CARTON QUANTITIES ONLY

PART NO.	HR #	DESCRIPTION	CTN QTY
B00011	609-N-6	Bracket with 1" hole	50

Turnout Bend Support for PEX



- PEX turnout bend support for potable water installations
- CARTON QUANTITIES ONLY

PART NO.	HR #	DESCRIPTION	CTN QTY
B00013	704	3/8" - 1/2"	50

Insert for CPVC



- Fire retardant plastic
- CARTON QUANTITIES ONLY

PART NO.	HR #	DESCRIPTION	CTN QTY
B00014	604	1/2" insert	100
B00015	605	3/4" insert	100

Metal Stud Insulator



- Fire retardant plastic
- Use for copper pipe
- CARTON QUANTITIES ONLY

PART NO.	HR #	DESCRIPTION	CTN QTY
B00016	404-R	1/2" insulator	100
B00017	405-R	3/4" insulator	100
B00018	406-R	1" insulator	100

Schedule 40 Pipe Hanger



- Alternating screw and nail holes
- Load rating 250# max

Galvanized		
PART NO.	SIZE	CTN QTY
H30001	1 1/2"	50
H30002	2"	50
H30003	3"	50
H30004	4"	50
Vinyl		
PART NO.	SIZE	CTN QTY
H30011	1 1/2"	100
H30022	2"	50
H30033	3"	50
H30044	4"	50

Plastic Coated Pipe Hook



- Steel pipe hook with plastic insulation

PART NO.	SIZE	CTN QTY
H12054	1/2" x 4"	50/1000
H12056	1/2" x 6"	50/1000
H12074	3/4" x 4"	50/1000
H12076	3/4" x 6"	50/1000
H12106	1" x 6"	50/1000

"Copper Boy" Pipe Hook



- CARTON QUANTITIES ONLY

PART NO.	DESCRIPTION	CTN/MSTR
H10052	1/2" x 2 1/2" copper clad pipe hook	50/2200
H10072	3/4" x 2 1/2" copper clad pipe hook	50/500

Drive J-Hook



- Copper clad
- CARTON QUANTITIES ONLY

PART NO.	CTS	CTN QTY
H23050	1/2" x 3/4"	100

Pipe Hook



Plain Steel



Copper Clad

- 10 gauge
- CARTON QUANTITIES ONLY

Plain Steel		
PART NO.	SIZE	CTN QTY
H10054	1/2" x 4"	50/500
H10056	1/2" x 6"	50/500
H10058	1/2" x 8"	50/500
H10074	3/4" x 4"	50/500
H10076	3/4" x 6"	50/500
H10078	3/4" x 8"	50/500
H10080	3/4" x 10"	50/500
H10106	1" x 6"	50/500
H10108	1" x 8"	50/500
H10110	1" x 10"	50/500
H10126	1 1/4" x 6"	50/500
H10128	1 1/4" x 8"	50/500
H10156	1 1/2" x 6"	50/500
H10158	1 1/2" x 8"	50/500
H10208	2" x 8"	50/500

Copper Clad		
PART NO.	SIZE	CTN QTY
H11054	1/2" x 4"	50/500
H11056	1 1/2" x 6"	50/500
H11058	1/2" x 8"	50/500
H11074	3/4" x 4"	50/500
H11076	3/4" x 6"	50/500
H11078	3/4" x 8"	50/500
H11080	3/4" x 10"	50/500
H11106	1" x 6"	50/500
H11108	1" x 8"	50/500
H11126	1 1/4" x 6"	50/500
H11156	1 1/2" x 6"	50/500
H11208	2" x 8"	50/500
H11210	2" x 10"	50/500

J-Hook for CTS Water System



- Nail holes on all four sides - nails are included!
- No heat distortion even at 250°
- Eliminates corrosion and electrolysis on copper pipe
- Fabricated of durable ABS plastic
- FULL BAG QUANTITIES ONLY

Baby J-Hooks		
PART NO.	DESCRIPTION	BAG/CTN QTY
J01050	1/2" CTS x 4" length	25/300
J01075	3/4" CTS x 4" length	25/300
J01100	1" CTS x 4" length	25/200

Long Baby J-Hooks		
PART NO.	DESCRIPTION	BAG/CTN QTY
J01057	1/2" CTS x 7 1/2" length	25/200
J01077	3/4" CTS x 7 1/2" length	25/200

Double J-Hooks		
PART NO.	DESCRIPTION	BAG/CTN QTY
J01051	1/2" CTS x 1/2" CTS x 4" length	25/200
J01052	1/2" CTS x 3/4" CTS x 4" length	25/200
J01053	3/4" CTS x 3/4" CTS x 4" length	25/200

J-Hook for Drain Pipe System



- Nails included
- Reduces installation time
- Glueable with universal cement
- Designed for PVC and ABS pipe
- Fabricated of durable ASB plastic
- Calibrated for 1/8" fall per foot - no more measuring & adjusting for fall
- FULL BAG QUANTITIES ONLY



PART NO.	DESCRIPTION	BAG/CTN QTY
J01150	1 1/2" DWV x 7" length	25/300
J01200	2" DWV x 7" length	25/300
J01300	3" DWV x 7" length	25/300
J01400	4" DWV x 7" length	25/300

Pipe Strap



- Priced each
- CARTON QUANTITIES ONLY

Two-Hole Galvanized - IPS

PART NO.	SIZE	CTN QTY
H13038	3/8"	200
H13050	1/2"	150
H13075	3/4"	50
H13100	1"	50
H13125	1 1/4"	50
H13150	1 1/2"	25
H13200	2"	25
H13250	2 1/2"	25
H13300	3"	10
H13400	4"	10

Two-Hole Copper Clad - CTS

PART NO.	SIZE	CTN QTY
H15050	1/2"	100
H15075	3/4"	100
H15100	1"	100
H15125	1 1/4"	100
H15150	1 1/2"	100
H15200	2"	100

Two-Hole Solid Copper - CTS

PART NO.	SIZE	CTN QTY
H16038	3/8"	100
H16050	1/2"	100
H16075	3/4"	100
H16100	1"	100

One-Hole Galvanized - IPS

PART NO.	SIZE	CTN QTY
H18050	1/2"	100
H18075	3/4"	100

Copper Clad Nail



- CARTON QUANTITIES ONLY

PART NO.	SIZE	CTN/MSTR
H15001	1 1/4"	200/2000

Copper Coated J-Nails



- CARTON QUANTITIES ONLY

PART NO.	SIZE	CTN/MSTR
H22050	1/2"	100/1300
H22075	3/4"	100/1300

Full Clamp



- Plastic clamp with preloaded nail for copper, CPVC, polybutylene tubing
- CARTON QUANTITIES ONLY

PART NO.	TUBING SIZE	CTN/MSTR
H25050	1/2"	100/4000
H25075	3/4"	50/2000
H25100	1"	25/1025

Half Clamp



- Plastic clamp with preloaded nail for copper, CPVC, polybutylene tubing
- CARTON QUANTITIES ONLY

PART NO.	TUBING SIZE	CTN/MSTR
H24038	3/8"	100/7500
H24050	1/2"	50/1000
H24075	3/4"	50/3000
H24100	1"	50/2000

Insulating/Suspension Clamp



- Plastic insulating and suspension clamp in one
- Eliminates noise from tubing expansion and contraction
- For copper, CPVC and polybutylene tubing
- CARTON QUANTITIES ONLY

PART NO.	TUBING SIZE	CTN/MSTR
H26050	1/2"	50/1000
H26075	3/4"	50/1000
H26100	1"	50/600
H26125	1 1/4"	50/500
H26150	1 1/2"	25/500
H26200	2"	25/350

Pipe Insulator



- Plastic insulator eliminates noise from expansion and contraction
- For copper, CPVC and polybutylene tubing
- UPC listed
- Drill hole size 1 3/8"
- CARTON QUANTITIES ONLY

PART NO.	TUBING SIZE	CTN/MSTR
H27050	1/2"	25/1000
H27075	3/4"	25/1000
H27100	1"	25/1000

Two-Hole Pipe Clamp



- Plastic clamp eliminates noise from tubing expansion and contraction
- Supports copper, CPVC and polybutylene tubing
- CARTON QUANTITIES ONLY

PART NO.	TUBING SIZE	CTN/MSTR
H28050	1/2"	100/1000
H28075	3/4"	100/1000
H28100	1"	50/500
H28125	1 1/4"	50/750
H28150	1 1/2"	25/500
H28200	2"	25/250

F.H.A. Tub Hanger



- 12 gauge galvanized steel
- Adjustable on stud
- CARTON QUANTITIES ONLY

PART NO.	DESCRIPTION	CTN QTY
T12001	Tub Hanger	100

Metal Stud Pipe Insulator



PART NO.	SIZE	CTN/MSTR
H29000	3/8", 1/2", 3/4"	50/500
H29010	1"	50/500

Earthquake Strap



- Holes are spread 1" apart on center

PART NO.	SIZE	GAUGE	CTN QTY
H20500	2" x 10'	22	10

Perforated Hanger Iron



- Alternating holes (bolt and nail)
- CARTON QUANTITIES ONLY

Galvanized

PART NO.	SIZE	GAUGE	CTN QTY
H20001	3/4" x 10'	20 (heavy)	50 rolls
H20002	3/4" x 10'	24 (medium)	50 rolls
H20003	3/4" x 10'	28 (light)	50 rolls
H20005	3/4" x 50'	20 (heavy)	10 rolls
H20006	3/4" x 50'	24 (medium)	10 rolls
H20007	3/4" x 50'	28 (light)	10 rolls
H20010	3/4" x 100'	20 (heavy)	5 rolls
H20011	3/4" x 100'	24 (medium)	10 rolls
H20012	3/4" x 100'	28 (light)	10 rolls

Copper Clad

PART NO.	SIZE	GAUGE	CTN QTY
H20100	3/4" x 10'	22 (heavy)	50 rolls
H20150	3/4" x 50'	22	10 rolls

Plastic Hanger Tape



- Flexible, non-conductive polypropylene
- 3/4" wide, .050 thick
- 1/8" diameter holes every 3/4"
- 125 lb. ultimate load ASTM A-370-77
- Can be cut with scissors or utility knife
- Uses: pipe hanger, duct hanger and tubing utility strapping

PART NO.	DESCRIPTION	CTN/MSTR
H21010	10' roll poly bagged	1/200
H21025	25' roll poly bagged	1/50
H21050	50' roll poly bagged	1/20
H21100	100' roll poly bagged	1/30
H21101	100' roll dispenser box	1/25

Plastic Hanger Tape



- 125# max load
- 1/8" diameter holes every 3/4"
- 2" wide; .05 thickness; cuts with scissors

PART NO.	SIZE	CTN/MSTR
H21200	2" x 100'	1/5

Mason's Nylon Twine



- Approximately 165 lb. break strength
- Twisted yellow twine

PART NO.	DESCRIPTION	CTN/MSTR
T60001	#18 x 225'	24/192
T60000	#18 x 1100'	12/72

Binder Sisal Twine



• Used to tie down material for hauling

PART NO.	DESCRIPTION	CTN/MSTR
T60002	5 lb. bale (approx. 2500')	1/8

Candle Wick Packing



• Medium packing in 2 ounce balls

PART NO.	DESCRIPTION	CTN/MSTR
T60003	Candle wick packing	12/396

Graphite Packing



• Non-asbestos material in resealable spoos

PART NO.	DESCRIPTION	CTN/MSTR
T60005	1/8" diameter x 12' spool	12/120
T60006	1/4" diameter x 8' spool	12/120

Oakum



• The original Oakum with benonite-expands over 10 times when wet
 • Baled in coils or cut length for easy use
 • No tar in brown oakum
 • CARTON QUANTITIES ONLY (except 1 lb. bags)

PART NO.	DESCRIPTION	INNER PACK	CTN/MSTR
O15001	Brown random cut	10 - 5 lb. bags	1
O15002	White 3/8" cord	6 - 10 lb. coils	1
O15003	White 3/8" cord (27" cut length)	10 - 5 lb. bags	1
O15006	Brown random cut	1 lb. bags	1/20
O15007	White 3/8" cord (27" cut length)	1 lb. bags	1/20

Lead Wool



• Five pound box

PART NO.	SIZE	CTN/MSTR
L40001	5 pounds	1/10

Lead Ingot



L42002



L42052

PART NO.	SIZE	CTN QTY
L40002	25 pounds (Handle w/ four 5 lb. plugs)	1
L42052	5 pounds	1

Lead Melting Pot



• Wire handle

PART NO.	SIZE	CTN QTY
L42006	6" pot	1
L42008	8" pot	1

Lead Pouring Ladle



• Wrought steel

PART NO.	SIZE	CTN/MSTR
L42102	3" ladle	1/100
L42103	3 1/2" ladle	1/50
L42104	4" ladle	1/50

Drum Trap Cover



• Flanged, plated die cast
 • Cover supplied with gasket
 • D02-002 CARTON QUANTITIES ONLY

PART NO.	DESCRIPTION	CTN/MSTR
D02001	Cover and gasket	1/100
D02002	Gasket only	25/100
P55300	Rough brass cover	1/60

Trap Covers



C98001



C98002

• Stainless steel

PART NO.	DESCRIPTION	CTN/MSTR
C98001	5 3/4" flat SS trap cover	150/300
C98002	5 3/4" raised SS trap cover	50/200

Wet-R-Dri Roofing Cement



• All-weather plastic
 • Chemically fortified to bond to water-covered, damp or dry surfaces
 • Great for emergency repairs under wet conditions

PART NO.	DESCRIPTION	CTN/MSTR
C09000	5 gallon can	1/1
C09001	One gallon can	1/6
C09002	10.5 ounce cartridge	1/12

Foundation and Roof Coating



- Non-fibered liquid damp-proof seal
- All weather plastic
- Chemically fortified to bond to water covered, damp or dry surfaces
- Great for emergency repairs under wet conditions

PART NO.	DESCRIPTION	CTN/MSTR
C09003	1 Gal. Foundation and Roof Coating	1/6

Sewage Ejector/Sump Pump Check Valve



- Couplings are sized for IPS ID hose
- Combination unit for 1 1/2" and 1 1/4" IPS, 1 1/2" copper

PART NO.	DESCRIPTION	CTN/MSTR
C29150	1 1/2" slip x 1 1/2" slip	1/50
C29200	2" slip x 2" slip	1/50
C29126	1 1/4" slip x 1 1/2" slip	1/50

Flexible Discharge Hose



- Ideal for sump pumps, centrifugal pumps, and submersible pumps
- Complete kit includes 24' hose, 1 1/4" adapter and steel clamp

PART NO.	DESCRIPTION	CTN/MSTR
C29123	1 1/2" Flex Discharge Hose Kit	1/5
C29124	1 1/4" Complete Kit	1/5

Roofite® Hi-Heat Silicone Flashing



- Silicone range is designed for high temperature applications up to 390°F
- Ideal for corrugated metal roofs
- Can be used on flat roofs
- Pipe diameter markings
- For plumbing, heating, air conditioning, electrical or exhaust vents
- Pleated cone adjusts to any pitch up to 45° F
- Ozone and UV resistant

PART NO.	SIZE	CTN/MSTR
R16100	0"-2 3/4"	1/25
R16101	2"-6 1/8"	1/20
R16107	6"-10 1/32"	1/10
R16108	9 1/2"-14 3/4"	1/10

Roofite® Roof Flashing



- Ideal for corrugated metal roofs
- Can be used on flat roofs
- Pipe diameter markings
- For plumbing, heating, air conditioning, electrical or exhaust vents
- Made of EPDM with flexible aluminum base
- Pleated cone adjusts to any pitch
- -30°F to +250°F
- Ozone and UV resistant

PART NO.	SIZE	CTN/MSTR
R15109	0"-1 1/4"	1/20
R15100	0"-2 3/4" pipe	1/20
R15101	2"-6 1/8" pipe	1/20
R15107	6"-10 1/32" pipe	1/10
R15108	9 1/2"-14 3/4" pipe	1/10

Galvanized Roof Flashing



- Double seal neoprene collar
- UPC, BOCA ad SBCCI approved

PART NO.	SIZE	FLANGE	CTN/MSTR
R40150	1 1/4" and 1 1/2"	8 3/4" x 12 1/2"	1/12
R40200	2"	8 3/4" x 12 1/2"	1/12
R40300	3"	10 3/4" x 14 1/2"	1/12
R40400	4"	12" x 16"	1/12

Aluminum Roof Flashing



- Double seal neoprene collar

PART NO.	SIZE	FLANGE	CTN/MSTR
R45150	1 1/4" and 1 1/2"	8 3/4" x 12 1/2"	1/12
R45200	2"	8 3/4" x 12 1/2"	1/12
R45300	3"	10 3/4" x 14 1/2"	1/12
R45400	4"	12" x 16"	1/12

All Neoprene Roof Flashing



- Double seal neoprene collar

PART NO.	SIZE	FLANGE	CTN/MSTR
R50150	1 1/4" and 1 1/2"	9" x 11 3/8"	1/20
R50200	2"	9" x 11 3/8"	1/20
R50300	3"	10" x 13 1/4"	1/20
R50400	4"	12" x 14 3/4"	1/20

Neo-poly Roof Flashing



- Poly vinyl base
- Neoprene collar

PART NO.	SIZE	FLANGE	CTN/MSTR
R57150	1 1/4" and 1 1/2"	9 1/4" x 13"	1/12
R57200	2"	9 1/4" x 13"	1/12
R57300	3"	11 1/8" x 15"	1/12
R57400	4"	12" x 15 1/2"	1/12

Lead Roof Flashing



- Southeastern Code
- 2 1/2 pounds
- Multi-pitch from flat to 7/12"
- CARTON QUANTITIES ONLY

PART NO.	SIZE	FLANGE	CTN QTY
R70150	1 1/2"	8 1/2" x 10 1/2"	12
R70200	2"	8 1/2" x 10 1/2"	12
R70300	3"	10 1/2" x 11 1/2"	6
R70400	4"	10 1/2" x 11 1/4"	6

Instant Sealant



- Flame resistant
- Fills holes and cracks
- Deadens sound
- Insulates against air conditioning and heat loss
- Prevents passage of dirt, water and insects
- Both 12 and 24 oz. cans spray in any position
- UPS GROUND AND MOTOR FREIGHT ONLY
- CARTON QUANTITIES ONLY

PART NO.	DESCRIPTION	CTN QTY
S30012	12 oz. cans	12
S30024	24 oz. cans	12

Hose and Hose Bracket for Service Sink



- Heavy duty 300 cloth-reinforced 5/8" rubber hose (2 1/2" long)
- 3/4" brass hose coupling at one end
- 5" x 3" stainless steel bracket with rubber grip

PART NO.	DESCRIPTION	CTN/MSTR
M05001	Hose with bracket	1
M05005	Bracket only	1/25

Mop Hanger for Service Sink



- 24" x 3" stainless steel hanger with three rubber tool grips
- Anchors included

PART NO.	DESCRIPTION	CTN/MSTR
M05003	Mop hanger	1/5

Anchor Bolt Kit



- Includes anchors, hex head screws and drill bit

PART NO.	SIZE	PIECES	DRILL BIT	CTN/MSTR
A33001	#8 x 1"	100	3/16"	1/50
A33002	#10 x 1 1/4"	100	1/4"	1/36
A33005	#14 x 1 1/2"	50	5/16"	1/36

Stove Bolt with Nut



- Zinc plated
- CARTON QUANTITIES ONLY

PART NO.	SIZE	CTN QTY
F33009	3/16" x 3/4"	100
F33010	1/4" x 3/4"	100
F33011	1/4" x 1"	100
F33012	1/4" x 1 1/4"	100
F33013	1/4" x 1 1/2"	100
F33014	1/4" x 2"	100

Flat Phillips Head Brass Wood Screw



- Flat Phillips head
- Solid brass construction
- CARTON QUANTITIES ONLY

PART NO.	SIZE	CTN QTY
F33300	#12 x 1 1/4"	100
F33301	#12 x 1 1/2"	100
F33302	#12 x 2"	100
F33303	#14 x 1 1/4"	100

Phillips Head Wood Screw



- Zinc plated
- CARTON QUANTITIES ONLY

PART NO.	SIZE	CTN QTY
F33030	#10 x 1 1/2"	100
F33031	#12 x 1"	100
F33032	#12 x 1 1/4"	100
F33033	#12 x 1 1/2"	100
F33034	#12 x 2"	100
F33035	#12 x 2 1/2"	100
F33036	#12 x 3"	100
F33037	#14 x 1 1/4"	100
F33038	#14 x 1 1/2"	100
F33039	#14 x 2"	100
F33040	#14 x 2 1/2"	100
F33041	#14 x 3"	100

Hex Head Lag Screw



- CARTON QUANTITIES ONLY

PART NO.	SIZE	CTN QTY
F33140	3/8" x 1"	100
F33141	3/8" x 1 1/2"	100
F33142	3/8" x 2"	100
F33143	3/8" x 2 1/2"	50
F33144	3/8" x 3"	50

E-Z Anchor/Self-Drilling Wall Board



- Die cast zinc
- Installs with #2 Phillips screwdriver
- CARTON QUANTITIES ONLY

PART NO.	DESCRIPTION	CTN QTY
A33010	E-Z Anchor with 1 1/4" screws	10

Toggle Bolt



Toggle Bolt



Toggle Wing

- Zinc plated
- Spring loaded wing
- CARTON QUANTITIES ONLY

PART NO.	SIZE	CTN QTY
F33060	3/16" x 3/4"	50
F33061	1/4" x 3"	50
F33062	1/4" x 4"	50
F33063	1/4" x 6"	50
F33064	3/8" x 4"	50
F33065	3/8" x 6"	50
Toggle Wing Only		
PART NO.	SIZE	CTN QTY
F33066	3/16"	100
F33067	1/4"	100
F33068	3/8"	100
F33069	1/2"	100

Hex Head Tapping Screw



- Zinc plated
- CARTON QUANTITIES ONLY

PART NO.	SIZE	CTN QTY
F33101	#7 x 1/2"	100
F33102	#7 x 1/2"	1000
F33103	#8 x 1/2"	100
F33104	#8 x 1/2"	1000
F33105	#8 x 3/4"	100
F33106	#8 x 3/4"	1000
F33107	#8 x 1"	100
F33108	#8 x 1"	500
F33109	#8 x 1 1/2"	50
F33110	#8 x 1 1/2"	500
F33111	#8 x 2"	50
F33112	#8 x 2"	250
F33113	#10 x 3/4"	100
F33114	#10 x 3/4"	1000
F33115	#10 x 1"	100
F33116	#10 x 1"	500

Drill Point Tech Screw



- CARTON QUANTITIES ONLY

PART NO.	SIZE	CTN QTY
F33120	#8 x 1/2"	100
F33121	#8 x 1/2"	500
F33122	#8 x 3/4"	100
F33123	#8 x 3/4"	500
F33124	#10 x 3/4"	100
F33125	#10 x 3/4"	500
F33126	#10 x 1"	100
F33127	#10 x 1"	500
F33128	#10 x 1 1/2"	100
F33129	#12 x 3/4"	100
F33130	#12 x 1"	100
F33131	#12 x 1 1/2"	100
F33132	#12 x 2"	100

Hex Nut



- Zinc plated
- CARTON QUANTITIES ONLY

PART NO.	SIZE	CTN QTY
F33080	1/4" - 20	100
F33081	5/16" - 18	100
F33082	3/8" - 16	100
F33083	1/2" - 13	50

Zinc Plated Fender Washer



- CARTON QUANTITIES ONLY

PART NO.	SIZE	OD	CTN QTY
F33098	1/4"	1 1/2"	100
F33096	3/8"	1 1/2"	100
F33097	1/2"	2"	100

Flat Washer



- Zinc plated
- CARTON QUANTITIES ONLY

PART NO.	SIZE	OD	CTN QTY
F33094	3/8"	1"	100
F33095	1/2"	1 3/8"	100

Carrier Nuts and Washer Set



- 4 nuts and washers
- 5/8 - 11 threads
- Much lower cost than specification companies

PART NO.	DESCRIPTION	CTN/MSTR
C56100	Carrier nuts and washer set (4-pack)	1/100

Universal Beam Clamp



- 3/8" UNC bolt thread
- Steel set screw

PART NO.	SIZE	ROD SIZE	CTN QTY
H60375	3/8"	3/8"	25
H60050	1/2"	1/2"	25
H60625	5/8"	5/8"	25
H60075	3/4"	3/4"	25

Copper Pipe Hangers - Bell & Milford Types



Bell Type



Milford Type

- Copper clad

Bell Type		
PART NO.	SIZE	CTN/MSTR
H83050	1/2"	25/500
H83075	3/4"	25/500
H83100	1"	25/500
Milford Type		
PART NO.	SIZE	CTN QTY
H84050	1/2" x 6"	25
H84075	3/4" x 6"	25
H84100	1" x 6"	25
H85050	1/2" x 12"	25
H85075	3/4" x 12"	25
H85100	1" x 12"	25

Conduit Hangers



- Packed with bolts and nuts
- CARTON QUANTITIES ONLY

Zinc Plated				
PART NO.	CODE NO.	RIGID	THIN WALL	CTN QTY
H14050	0	1/2"-3/8"	1/2"	100
H14075	1	3/4"	3/4"	50
H14100	2	1"	1"	50
H14125	3	1 1/4"	-	50
H14150	4	1 1/2"	1 1/2"	25
H14200	5	2"	2"	25
H14250	6	2 1/2"	-	10
H14300	7	3"	-	10
H14350	8	3 1/2"	-	10
H14400	9	4"	-	10

Copper Plated				
PART NO.	CODE NO.	RIGID	THIN WALL	CTN QTY
H17050	0	1/2"-3/8"	1/2"	100
H17075	1	3/4"	3/4"	100
H17100	2	1"	1"	50
H17125	3	1 1/4"	-	50
H17150	4	1 1/2"	1 1/2"	25
H17200	5	2"	2"	25
H17250	6	2 1/2"	-	25
H17300	7	3"	-	25
H17350	8	3 1/2"	-	25
H17400	9	4"	-	25

Swivel Ring



- Supplied with nuts

Zinc Plated			
PART NO.	SIZE	ROD SIZE	CTN QTY
H65050	1/2"	3/8"	25
H65075	3/4"	3/8"	25
H65100	1"	3/8"	25
H65125	1 1/4"	3/8"	25
H65150	1 1/2"	3/8"	25
H65200	2"	1/2"	20
H65250	2 1/2"	1/2"	20
H65300	3"	1/2"	10
H65400	4"	1/2"	10
H65500	5"	1/2"	5
H65600	6"	1/2"	5

Copper Plated			
PART NO.	SIZE	ROD SIZE	CTN QTY
H66050	1/2"	3/8"	25
H66075	3/4"	3/8"	25
H66100	1"	3/8"	25
H66125	1 1/4"	3/8"	25
H66150	1 1/2"	3/8"	25
H66200	2"	1/2"	20
H66250	2 1/2"	1/2"	20
H66300	3"	1/2"	10
H66400	4"	1/2"	10

Zinc Plated Clevis Hanger



Standard - 401# Steel			
PART NO.	SIZE	ROD SIZE	CTN QTY
H68050	1/2"	3/8"	25
H68075	3/4"	3/8"	25
H68100	1"	3/8"	25
H68125	1 1/4"	3/8"	25
H68150	1 1/2"	3/8"	25
H68200	2"	3/8"	20
H68250	2 1/2"	1/2"	20
H68300	3"	1/2"	10
H68350	3 1/2"	1/2"	10
H68400	4"	5/8"	10
H68500	5"	5/8"	5
H68600	6"	3/4"	5
H68800	8"	7/8"	5
Light Duty - 400# Steel			
PART NO.	SIZE	ROD SIZE	CTN QTY
H69050	1/2"	3/8"	25
H69075	3/4"	3/8"	25
H69100	1"	3/8"	25
H69150	1 1/2"	3/8"	25
H69200	2"	3/8"	20
H69250	2 1/2"	1/2"	20
H69300	3"	1/2"	10
H69400	4"	5/8"	10

Riser Clamp



• For Schedule 40 iron pipe only - Not for soil pipe

PART NO.	SIZE	OVERALL WIDTH	CTN QTY
H70050	1/2"	9 3/8"	25
H70075	3/4"	9 3/8"	25
H70100	1"	9 3/8"	25
H70125	1 1/4"	10"	25
H70150	1 1/2"	10 3/8"	25
H70200	2"	10 7/8"	25
H70250	2 1/2"	11 1/4"	25
H70300	3"	11 3/4"	10
H70350	3 1/2"	13 1/4"	10
H70400	4"	13 1/2"	10

Hinged Split Ring



Zinc Plated for Iron Pipe			
PART NO.	SIZE	ROD SIZE	CTN QTY
H72375	3/8"	3/8"	25
H72050	1/2"	3/8"	25
H72075	3/4"	3/8"	25
H72100	1"	3/8"	25
H72125	1 1/4"	3/8"	25
H72150	1 1/2"	3/8"	25
H72200	2"	3/8"	20
H72250	2 1/2"	1/2"	20
H72300	3"	1/2"	10
H72400	4"	1/2"	10
Copper Plated for Copper Tube			
PART NO.	SIZE	ROD SIZE	CTN QTY
H73375	3/8"	3/8"	25
H73050	1/2"	3/8"	25
H73075	3/4"	3/8"	25
H73100	1"	3/8"	25
H73125	1 1/4"	3/8"	25
H73150	1 1/2"	3/8"	25
H73200	2"	3/8"	10

Ceiling Flange

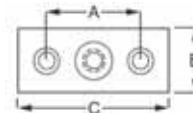

DIMENSIONS		
A	B	C
2"	1 3/8"	2 3/4"

PART NO.	SIZE	CTN QTY
H80375	3/8" plain finish	25
H80050	1/2" plain finish	25
H81375	3/8" zinc finish	25
H81050	1/2" zinc finish	25
H82375	3/8" copper finish	25
H82050	1/2" copper finish	25

Threaded Steel Rod



• Priced per rod
• CARTON QUANTITIES ONLY

PART NO.	DESCRIPTION	CTN QTY
T38006	3/8" x 6' plain finish	25
T38010	3/8" x 10' plain finish	25
T12006	1/2" x 6' plain finish	12
T12010	1/2" x 10' plain finish	12
T38106	3/8" x 6' zinc finish	25
T38110	3/8" x 10' zinc finish	25
T12106	1/2" x 6' zinc finish	12
T12110	1/2" x 10' zinc finish	12

Drop-In Concrete Anchor



- Priced per rod
- CARTON QUANTITIES ONLY

PART NO.	DESCRIPTION	CTN/MSTR
T38038	3/8" Drop-In Anchor	50/900
T12050	1/2" Drop-In Anchor	50/500

Rod Coupling Nut



- Hex, zinc plated, carbon steel

PART NO.	DESCRIPTION	CTN/MSTR
R60001	1/4" x 7/8"	50/1000
R60002	3/8" x 1 3/4"	50/1000
R60003	1/2" x 1 3/4"	50/1000
R60004	5/8" x 2 1/8"	50/200

Water Meter Box Keys and Covers



- All brass



PART NO.	DESCRIPTION	CTN/MSTR
M07001	Meter box key	1/100
M07002	Combination key and wrench	1/50
M25900	Penta head meter box and roadway box wrench	1/15

Water Meter Coupling Complete



- Heavy cast brass
- Complete with gasket
- LEAD FREE

PART NO.	SIZE	NPSM	LENGTH	NPT	CTN/MSTR
M20058	1/2"	3/4"	2 3/8"	1/2"	25/100
M20075	3/4"	1"	2 1/2"	3/4"	1/100
M20100	1"	1 1/4"	2 5/8"	1"	1/100

Gasket Only for Water Meter Couplings



- CARTON QUANTITIES ONLY

PART NO.	DESCRIPTION	CTN QTY
M20581	5/8" gasket for coupling	25
M20751	3/4" gasket for coupling	25
M20101	1" gasket for coupling	25

10" Economy Meter Box

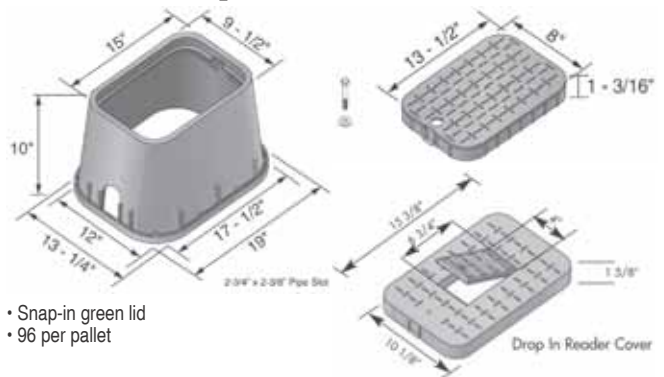

- Snap-in green lid
- 96 per pallet

PART NO.	DESCRIPTION	CTN/MSTR
M06001	10" rectangular box and lid	1/96
M06002	10" green snap-in lid only	1

Note: All items shown are for non-vehicular applications. Concrete and asphalt installations are not recommended for plastic parts.

12" Water Meter Box

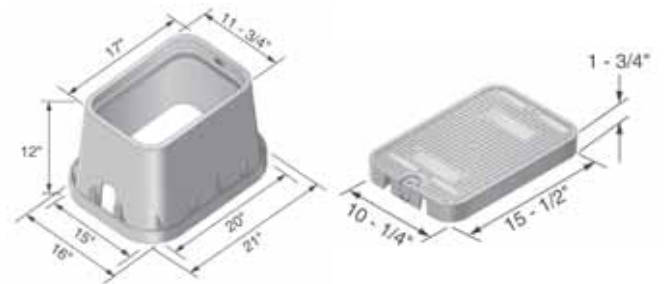

PART NO.	DESCRIPTION	CTN/MSTR
M12001	12" box and solid green lid	1/72
M12002	12" box and black reader lid	1/72
M12022	12" box and lid marked "sewer"	1/72
M12003	6" extension	1/42
M12005	12" solid green lid only	1
M12006	12" black reader lid only	1
M12009	12" box and solid black lid	1/72

Note: All items shown are for non-vehicular applications. Concrete and asphalt installations are not recommended for plastic parts.

12" Water Meter Box with Solid Cast Iron Lid



PART NO.	DESCRIPTION	CTN QTY
M12100	12" box with cast iron lid	1
M12085	Cast iron cover only	1

Note: All items shown are for non-vehicular applications. Concrete and asphalt installations are not recommended for plastic parts.

12" Standard Meter Box with Plastic Lid and Cast Iron Reader

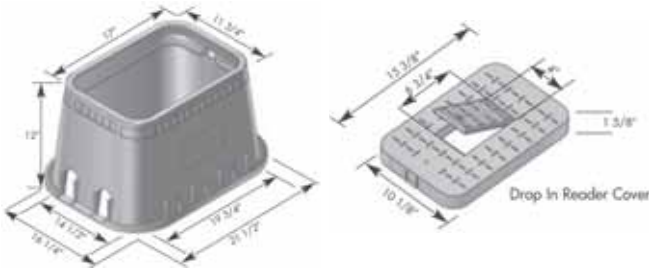

• 72 per pallet

PART NO.	DESCRIPTION	CTN QTY
M12004	12" box with plastic lid & cast iron reader	1

Note: All items shown are for non-vehicular applications. Concrete and asphalt installations are not recommended for plastic parts.

12" Irrigation Box (6" Deep)

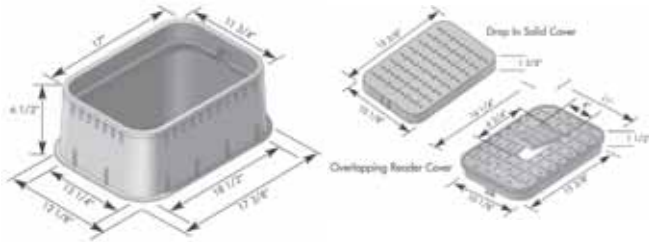

PART NO.	DESCRIPTION	CTN QTY
M12007	6" depth with green lid	1
M12005	12" solid green lid only	1
M12006	12" black reader lid only	1
M12008	12" valve box 6" deep with reader lid	1

Note: All items shown are for non-vehicular applications. Concrete and asphalt installations are not recommended for plastic parts.

15" Jumbo Water Meter Boxes

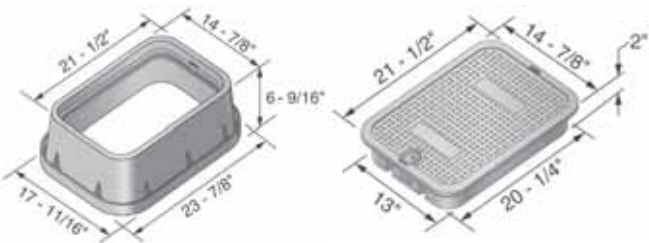

PART NO.	DESCRIPTION	CTN/MSTR
M15001	15" box and green solid lid	1/48
M15009	6" extension for M15001	1/36
M15002	15" box and black reader lid	1/48
M15004	15" solid green lid only	1
M15005	15" black reader lid only	1
M15006	6" extension with solid green lid	1

Note: All items shown are for non-vehicular applications. Concrete and asphalt installations are not recommended for plastic parts.

6" Residential Valve Boxes

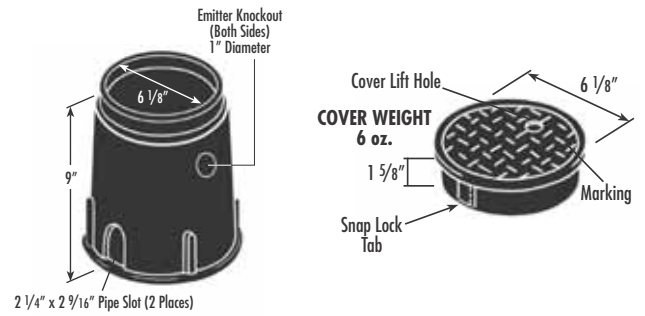

- Snap-in green lid
- Overlapping cover keeps dirt or grass from between body and lid
- Valve box can be extended with any 6" plastic or iron pipe
- 36 per carton

PART NO.	DESCRIPTION	CTN/MSTR
M06006	6" valve box 9" tall	1/36
M06007	6" green snap-in lid only	1

Note: All items shown are for non-vehicular applications. Concrete and asphalt installations are not recommended for plastic parts.

10" Round Valve Boxes

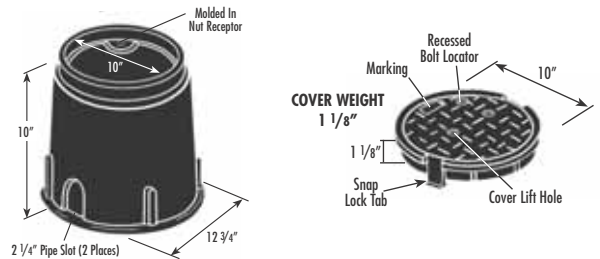

- Snap-in green lid
- Overlapping cover keeps dirt or grass from between body and lid
- 99 per pallet

PART NO.	DESCRIPTION	CTN QTY
M06010	10" round body and green lid	1/180

Note: All items shown are for non-vehicular applications. Concrete and asphalt installations are not recommended for plastic parts.

Shipping Boxes



- 32 ECT board test
- Kraft (brown)
- 200 pound burst strength
- BUNDLE QUANTITIES ONLY

PART NO.	SIZE	CTN/MSTR
BOX012	12 3/4"L x 12 3/4"W x 13 1/2"D	1/20
BOX011	11 1/8"L x 11 1/8"W x 9 1/8"D	1/20
BOX008	8"L x 8"W x 8"D	1/20
BOX006	6"L x 6"W x 8"D	1/20

Bin Boxes



PART NO.	SIZE	CTN/MSTR
BIN004	4"L x 12"W x 6 5/8"D	1/20
BIN005	5 1/4"L x 11 3/4"W x 6"D	1/20
BIN008	8"L x 12 1/4"W x 7 1/2"D	1/20
BIN012	12"L x 12 3/8"W x 7 1/2"D	1/20

Plastic Tub Box



PART NO.	SIZE	CTN QTY
T40001	13"L x 13"W x 7"D	1
T40002	12"L x 8 1/8"W x 6 1/2"D	1

Cardboard Tub Box



PART NO.	SIZE	CTN/MSTR
T40003	12"L x 8"W x 8 1/2"D wax coated	1/10
T40004	14 1/2"L x 11 5/16"W x 6"D wax coated	1/10
T40005	15"L x 12"W x 9"D	1/10
T40007	12"L x 12"W x 9"D	1/10
T40008	12"L x 12"W x 12"D non-coated	1/10